

ASME B30.2-2011
(Revision of ASME B30.2-2005)

Overhead and Gantry Cranes

(Top Running Bridge, Single or
Multiple Girder, Top Running
Trolley Hoist)

**Safety Standard for Cableways,
Cranes, Derricks, Hoists, Hooks, Jacks,
and Slings**

AN AMERICAN NATIONAL STANDARD



The American Society of
Mechanical Engineers

INTENTIONALLY LEFT BLANK

ASME B30.2-2011
(Revision of ASME B30.2-2005)

Overhead and Gantry Cranes

(Top Running Bridge, Single or
Multiple Girder, Top Running
Trolley Hoist)

**Safety Standard for Cableways,
Cranes, Derricks, Hoists, Hooks, Jacks,
and Slings**

AN AMERICAN NATIONAL STANDARD



**The American Society of
Mechanical Engineers**

Three Park Avenue • New York, NY • 10016 USA

Date of Issuance: July 29, 2011

The next edition of this Standard is scheduled for publication in 2016. This Standard will become effective 1 year after the Date of Issuance. There will be no addenda issued to this edition.

ASME issues written replies to inquiries concerning interpretations of technical aspects of this Standard. Interpretations are published on the ASME Web site under the Committee Pages at <http://cstools.asme.org> as they are issued and will also be included with each edition.

ASME is the registered trademark of The American Society of Mechanical Engineers.

This code or standard was developed under procedures accredited as meeting the criteria for American National Standards. The Standards Committee that approved the code or standard was balanced to assure that individuals from competent and concerned interests have had an opportunity to participate. The proposed code or standard was made available for public review and comment that provides an opportunity for additional public input from industry, academia, regulatory agencies, and the public-at-large.

ASME does not “approve,” “rate,” or “endorse” any item, construction, proprietary device, or activity.

ASME does not take any position with respect to the validity of any patent rights asserted in connection with any items mentioned in this document, and does not undertake to insure anyone utilizing a standard against liability for infringement of any applicable letters patent, nor assumes any such liability. Users of a code or standard are expressly advised that determination of the validity of any such patent rights, and the risk of infringement of such rights, is entirely their own responsibility.

Participation by federal agency representative(s) or person(s) affiliated with industry is not to be interpreted as government or industry endorsement of this code or standard.

ASME accepts responsibility for only those interpretations of this document issued in accordance with the established ASME procedures and policies, which precludes the issuance of interpretations by individuals.

No part of this document may be reproduced in any form,
in an electronic retrieval system or otherwise,
without the prior written permission of the publisher.

The American Society of Mechanical Engineers
Three Park Avenue, New York, NY 10016-5990

Copyright © 2011 by
THE AMERICAN SOCIETY OF MECHANICAL ENGINEERS
All rights reserved
Printed in U.S.A.

CONTENTS

Foreword	v
Committee Roster	vi
B30 Standard Introduction	viii
Summary of Changes	xi
Chapter 2-0 Scope, Definitions, and References	1
Section 2-0.1 Scope of B30.2	1
Section 2-0.2 Definitions	1
Section 2-0.3 References	5
Chapter 2-1 General Construction and Installation	7
Section 2-1.1 Markings	7
Section 2-1.2 Clearances	7
Section 2-1.3 General Construction — Runways and Supporting Structure	8
Section 2-1.4 Crane Construction	8
Section 2-1.5 Cabs — Normal or Skeleton (if Provided)	8
Section 2-1.6 Lubrication	9
Section 2-1.7 Service Platforms (Footwalks)	9
Section 2-1.8 Stops and Bumpers	10
Section 2-1.9 Rail Sweeps	10
Section 2-1.10 Guards for Moving Parts	11
Section 2-1.11 Truck Frame Drop	11
Section 2-1.12 Brakes and Braking Means	11
Section 2-1.13 Electrical Equipment	12
Section 2-1.14 Hoisting Equipment	16
Section 2-1.15 Warning Devices or Means for a Crane With a Power-Travelling Mechanism	17
Section 2-1.16 Manual	17
Chapter 2-2 Inspection and Testing	18
Section 2-2.1 Inspection	18
Section 2-2.2 Rope Inspection	19
Section 2-2.3 Testing	20
Chapter 2-3 Operator Training and Operation	21
Section 2-3.1 Crane Operator Training	21
Section 2-3.2 Training for Persons Other Than Crane Operators	21
Section 2-3.3 Operation	21
Section 2-3.4 Planned Engineered Lifts	24
Section 2-3.5 Hoist Limit Devices (Switches)	24
Section 2-3.6 Signals	24
Section 2-3.7 Miscellaneous	26
Section 2-3.8 Crane Lockout/Tagout	26
Chapter 2-4 Maintenance Training and Maintenance	27
Section 2-4.1 Maintenance Training	27
Section 2-4.2 Crane Maintenance	27
Section 2-4.3 Rope Replacement and Maintenance	28
Section 2-4.4 Maintenance Records	29
Figures	
2-0.2-1 Cantilever Gantry Crane	2
2-0.2-2 Gantry Crane	3

2-0.2-3	Overhead Crane	3
2-0.2-4	Semigantry Crane	3
2-0.2-5	Wall Crane	3
2-1.13.3-1	Recommended Arrangement of Controllers or Master Switches (Three-Motor Crane)	14
2-1.13.3-2	Recommended Arrangement of Controllers or Master Switches (Four-Motor Crane)	14
2-1.13.3-3	Recommended Arrangement of Controllers (Pendant Push-Button Station Arrangement)	15
2-1.13.3-4	Recommended Arrangement of Controllers (Radio Crane Control Transmitter Lever Arrangement)	15
2-3.6.1-1	Standard Hand Signals for Controlling Overhead and Gantry Cranes	25

FOREWORD

This American National Standard, Safety Standard for Cableways, Cranes, Derricks, Hoists, Hooks, Jacks, and Slings, has been developed under the procedures accredited by the American National Standards Institute (formerly the United States of America Standards Institute). This Standard had its beginning in December 1916 when an eight-page Code of Safety Standards for Cranes, prepared by an ASME Committee on the Protection of Industrial Workers, was presented to the annual meeting of the ASME.

Meetings and discussions regarding safety on cranes, derricks, and hoists were held from 1920 to 1925, involving the ASME Safety Code Correlating Committee, the Association of Iron and Steel Electrical Engineers, the American Museum of Safety, the American Engineering Standards Committee (later changed to American Standards Association and subsequently to the USA Standards Institute), Department of Labor — State of New Jersey, Department of Labor and Industry — State of Pennsylvania, and the Locomotive Crane Manufacturers Association. On June 11, 1925, the American Engineering Standards Committee approved the ASME Safety Code Correlating Committee's recommendation and authorized the project with the U.S. Department of the Navy, Bureau of Yards and Docks, and ASME as sponsors.

In March 1926, invitations were issued to 50 organizations to appoint representatives to a Sectional Committee. The call for organization of this Sectional Committee was sent out October 2, 1926, and the committee organized November 4, 1926, with 57 members representing 29 national organizations. The Safety Code for Cranes, Derricks, and Hoists, ASA B30.2-1943, was created from the eight-page document referred to in the first paragraph. This document was reaffirmed in 1952 and widely accepted as a safety standard.

Due to changes in design, advancement in techniques, and general interest of labor and industry in safety, the Sectional Committee, under the joint sponsorship of ASME and the Naval Facilities Engineering Command, U.S. Department of the Navy, was reorganized as an American National Standards Committee on January 31, 1962, with 39 members representing 27 national organizations.

The format of the previous code was changed so that separate standards (each complete as to construction and installation; inspection, testing, and maintenance; and operation) will cover the different types of equipment included in the scope of B30.

In 1982, the Committee was reorganized as an Accredited Organization Committee, operating under procedures developed by the ASME and accredited by the American National Standards Institute.

This Standard presents a coordinated set of rules that may serve as a guide to government and other regulatory bodies and municipal authorities responsible for the guarding and inspection of the equipment falling within its scope. The suggestions leading to accident prevention are given both as mandatory and advisory provisions; compliance with both types may be required by employers of their employees.

In case of practical difficulties, new developments, or unnecessary hardship, the administrative or regulatory authority may grant variances from the literal requirements or permit the use of other devices or methods, but only when it is clearly evident that an equivalent degree of protection is thereby secured. To secure uniform application and interpretation of this Standard, administrative or regulatory authorities are urged to consult the B30 Committee, in accordance with the format described in Section IX, before rendering decisions on disputed points.

Safety codes and standards are intended to enhance public safety. Revisions result from committee consideration of factors such as technological advances, new data, and changing environmental and industry needs. Revisions do not imply that previous editions were inadequate.

In this Volume of the Standard, Chapter 2-3 has been revised and Maintenance has been moved to a new Chapter 2-4. This Standard was approved by the B30 Committee and by ASME, was approved by ANSI and designated as an American National Standard on May 31, 2011.

ASME B30 STANDARDS COMMITTEE

Safety Standard for Cableways, Cranes, Derricks, Hoists, Hooks, Jacks, and Slings

(The following is the roster of the Committee at the time of approval of this Standard.)

STANDARDS COMMITTEE OFFICERS

P. S. Zorich, *Chair*
R. M. Parnell, *Vice Chair*
K. M. Hyam, *Secretary*

STANDARDS COMMITTEE PERSONNEL

N. E. Andrew, Thyssen Krup Steel USA, LLC
T. L. Blaton, NACB Group, Inc.
W. T. Hargrove, *Alternate*, QinetiQ North America
R. E. Bluff IV, Gantry Constructors, Inc.
P. A. Boeckman, The Crosby Group, Inc.
R. J. Bolen, Consultant, E. I. DuPont
A. D. Brown, A. D. Brown Co.
M. E. Brunet, Manitowoc Cranes/The Manitowoc Crane Group
T. A. Christensen, Alliance of American Insurers/Liberty Mutual Insurance
M. W. Mills, *Alternate*, Liberty Mutual Group
B. D. Closson, Craft Forensic Services, Inc.
B. A. Pickett, *Alternate*, Forensic Engineering and Applied Science Institute
R. A. Dahlin, Walker Magnetics Group
K. M. Jankowski, *Alternate*, Walker Magnetics Group
L. D. DeMark, Equipment Training Solutions, LLC
D. Jordan, *Alternate*, BP America
D. W. Eckstine, Eckstine and Associates
H. G. Leidich, *Alternate*, Leidich Consulting Services
R. J. Edwards, NBIS, Product Safety and Development
J. L. Bury, *Alternate*, Putzmeister America
E. D. Fidler, Grove Crane/The Manitowoc Crane Group
J. L. Gordon, Acco Material Handling Solutions
N. C. Hargreaves, Terex Corp.
C. E. Imerman, *Alternate*, Link-Belt Construction Equipment Co.
J. J. Headley, Crane Institute of America
W. C. Dickinson, *Alternate*, Crane Industry Services, LLC
G. B. Hetherston, E. I. DuPont
K. M. Hyam, The American Society of Mechanical Engineers
C. W. Ireland, National Oilwell Varco
A. J. Egging, *Alternate*, National Oilwell Varco
D. C. Jackson, Tulsa Winch Group
W. E. Osborn, *Alternate*, Ingersoll Rand
P. R. Juhren, Morrow Equipment Co., LLC
M. J. Quinn, *Alternate*, Morrow Equipment Co., LLC
R. M. Kohner, Landmark Engineering Services
D. Duerr, *Alternate*, 2DM Associates, Inc.
C. E. Lucas, The Crosby Group, Inc.
F. P. Massaro, *Alternate*, Bishop Lifting Products, Inc.
A. J. Lusi, IUOE Local 542 JATC
D. W. Frantz, *Alternate*, Ohio Operating Engineers Local 18
E. K. Marburg, Columbus McKinnon Corp.
D. K. Huber, *Alternate*, Columbus McKinnon Corp.
L. D. Means, Means Engineering and Consulting/Wire Rope Technical Board
D. M. Sleightholm, *Alternate*, Bridon American Corp.
D. L. Morgan, Mission Support Alliance
C. Brewer, *Alternate*, Mission Support Alliance
G. L. Owens, Consultant
J. Sturm, *Alternate*, Crane's Aerial Truck Service
R. M. Parnell, Wire Rope Rigging Consultants/Industrial Training International, Inc.
J. Danielson, *Alternate*, Boeing
J. T. Perkins, Consultant
R. M. Cutshall, *Alternate*, Savannah River Nuclear Solutions
J. E. Richardson, U.S. Department of the Navy
M. M. Jaxheimer, *Alternate*, Navy Crane Center
D. W. Ritchie, David Ritchie Consultant, LLC
J. D. Wiethorn, *Alternate*, Haag Engineering Co.
J. W. Rowland III, Consultant
J. C. Ryan, Boh Brothers Construction Co.
A. R. Ruud, *Alternate*, Atkinson Construction
D. Sayenga, The Cardon Management Group
J. A. Gilbert, *Alternate*, Associated Wire Rope Fabricators
D. W. Smith, Chicago Bridge and Iron Co.
S. K. Rammelsburg, *Alternate*, Chicago Bridge and Iron Co.
W. J. Smith, Jr., NBIS Claims and Risk Management, Inc.
J. Schoppert, *Alternate*, NBIS Claims and Risk Management, Inc.
R. G. Strain, Advanced Crane Technologies, LLC
P. D. Sweeney, General Dynamics, Electric Boat
B. M. Casey, *Alternate*, Electric Boat
A. R. Toth, Morris Material Handling
J. D. Edmundson, *Alternate*, Morris Material Handling
B. E. Weir, Jr., Association of Union Constructors/Norris Brothers Co., Inc.
J. R. Schober, *Alternate*, American Bridge Co.
R. C. Wild, U.S. Army Corps of Engineers
E. B. Stewart, *Alternate*, U.S. Army Corps of Engineers
D. N. Wolff, National Crane/Manitowoc Crane Group
A. L. Calta, *Alternate*, National Crane/Manitowoc Crane Group
P. S. Zorich, RZP International Ltd.
H. W. Fair, *Alternate*, H. Fair Associates, Inc.

HONORARY MEMBERS

J. W. Downs, Downs Crane and Hoist Co.
J. L. Franks, Consultant
J. M. Klibert, Lift-All Co., Inc.
R. W. Parry, Consultant

B30.2 – SUBCOMMITTEE PERSONNEL

J. W. Rowland III , <i>Chair</i> , Consultant	L. D. Means , Means Engineering and Consulting/Wire Rope Technical Board
A. R. Toth , <i>Vice Chair</i> , Morris Material Handling	T. F. Pritchett , Crane Inspection Services
B. M. Casey , <i>Alternate</i> , Electric Boat	J. E. Pritchett , <i>Alternate</i> , Crane Inspection Services
C. E. Cotton , Navy Crane Center	G. V. Stanic , Globex Corp.
R. M. Cutshall , Savannah River Nuclear Solutions	D. Stevens , InTomes, LLC
J. L. Gordon , Acco Material Handling Solutions	B. Westerhopf , G.W. Becker, Inc.
J. B. Greenwood , Navy Crane Center	
C. W. McDaniel , Foley Material Handling Co.	

SAFETY STANDARD FOR CABLEWAYS, CRANES, DERRICKS, HOISTS, HOOKS, JACKS, AND SLINGS

(11)

B30 STANDARD INTRODUCTION

SECTION I: SCOPE

The ASME B30 Standard contains provisions that apply to the construction, installation, operation, inspection, testing, maintenance, and use of cranes and other lifting and material-movement related equipment. For the convenience of the reader, the Standard has been divided into separate volumes. Each volume has been written under the direction of the ASME B30 Standard Committee and has successfully completed a consensus approval process under the general auspices of the American National Standards Institute (ANSI).

As of the date of issuance of this Volume, the B30 Standard comprises the following volumes:

- B30.1 Jacks, Industrial Rollers, Air Casters, and Hydraulic Gantries
- B30.2 Overhead and Gantry Cranes (Top Running Bridge, Single or Multiple Girder, Top Running Trolley Hoist)
- B30.3 Tower Cranes
- B30.4 Portal and Pedestal Cranes
- B30.5 Mobile and Locomotive Cranes
- B30.6 Derricks
- B30.7 Winches
- B30.8 Floating Cranes and Floating Derricks
- B30.9 Slings
- B30.10 Hooks
- B30.11 Monorails and Underhung Cranes
- B30.12 Handling Loads Suspended From Rotorcraft
- B30.13 Storage/Retrieval (S/R) Machines and Associated Equipment
- B30.14 Side Boom Tractors
- B30.15 Mobile Hydraulic Cranes (withdrawn 1982 — requirements found in latest revision of B30.5)
- B30.16 Overhead Hoists (Underhung)
- B30.17 Overhead and Gantry Cranes (Top Running Bridge, Single Girder, Underhung Hoist)
- B30.18 Stacker Cranes (Top or Under Running Bridge, Multiple Girder With Top or Under Running Trolley Hoist)
- B30.19 Cableways
- B30.20 Below-the-Hook Lifting Devices
- B30.21 Manually Lever-Operated Hoists
- B30.22 Articulating Boom Cranes

- B30.23 Personnel Lifting Systems
- B30.24 Container Cranes
- B30.25 Scrap and Material Handlers
- B30.26 Rigging Hardware
- B30.27 Material Placement Systems
- B30.28 Balance Lifting Units
- B30.29 Self-Erect Tower Cranes¹

SECTION II: SCOPE EXCLUSIONS

Any exclusion of, or limitations applicable to the equipment, requirements, recommendations or operations contained in this Standard are established in the affected Volume's scope.

SECTION III: PURPOSE

The B30 Standard is intended to

(a) prevent or minimize injury to workers, and otherwise provide for the protection of life, limb, and property by prescribing safety requirements

(b) provide direction to manufacturers, owners, employers, users, and others concerned with, or responsible for, its application

(c) guide governments and other regulatory bodies in the development, promulgation, and enforcement of appropriate safety directives

SECTION IV: USE BY REGULATORY AGENCIES

These Volumes may be adopted in whole or in part for governmental or regulatory use. If adopted for governmental use, the references to other national codes and standards in the specific volumes may be changed to refer to the corresponding regulations of the governmental authorities.

SECTION V: EFFECTIVE DATE

(a) *Effective Date.* The effective date of this Volume of the B30 Standard shall be 1 yr after its date of issuance. Construction, installation, inspection, testing, maintenance, and operation of equipment manufactured and

¹ This volume is currently in the development process.

facilities constructed after the effective date of this Volume shall conform to the mandatory requirements of this Volume.

(b) *Existing Installations.* Equipment manufactured and facilities constructed prior to the effective date of this Volume of the B30 Standard shall be subject to the inspection, testing, maintenance, and operation requirements of this Standard after the effective date.

It is not the intent of this Volume of the B30 Standard to require retrofitting of existing equipment. However, when an item is being modified, its performance requirements shall be reviewed relative to the requirements within the current volume. The need to meet the current requirements shall be evaluated by a qualified person selected by the owner (user). Recommended changes shall be made by the owner (user) within 1 yr.

SECTION VI: REQUIREMENTS AND RECOMMENDATIONS

Requirements of this Standard are characterized by use of the word *shall*. Recommendations of this Standard are characterized by the word *should*.

SECTION VII: USE OF MEASUREMENT UNITS

This Standard contains SI (metric) units as well as U.S. Customary units. The values stated in U.S. Customary units are to be regarded as the standard. The SI units are a direct (soft) conversion from the U.S. Customary units.

SECTION VIII: REQUESTS FOR REVISION

The B30 Standard Committee will consider requests for revision of any of the volumes within the B30 Standard. Such requests should be directed to

Secretary, B30 Standard Committee
ASME Codes and Standards
Three Park Avenue
New York, NY 10016-5990

Requests should be in the following format:

Volume: Cite the designation and title of the volume.
Edition: Cite the applicable edition of the volume.
Subject: Cite the applicable paragraph number(s) and the relevant heading(s).
Request: Indicate the suggested revision.
Rationale: State the rationale for the suggested revision.

Upon receipt by the Secretary, the request will be forwarded to the relevant B30 Subcommittee for consideration and action. Correspondence will be provided to

the requester defining the actions undertaken by the B30 Standard Committee.

SECTION IX: REQUESTS FOR INTERPRETATION

The B30 Standard Committee will render an interpretation of the provisions of the B30 Standard. Such requests should be directed to

Secretary, B30 Standard Committee
ASME Codes and Standards
Three Park Avenue
New York, NY 10016-5990

Requests should be in the following format:

Volume: Cite the designation and title of the volume.
Edition: Cite the applicable edition of the volume.
Subject: Cite the applicable paragraph number(s) and the relevant heading(s).
Question: Phrase the question as a request for an interpretation of a specific provision suitable for general understanding and use, not as a request for approval of a proprietary design or situation. Plans or drawings that explain the question may be submitted to clarify the question. However, they should not contain any proprietary names or information.

Upon receipt by the Secretary, the request will be forwarded to the relevant B30 Subcommittee for a draft response, which will then be subject to approval by the B30 Standard Committee prior to its formal issuance.

Interpretations to the B30 Standard will be published in the subsequent edition of the respective volume, and will be available online at <http://cstools.asme.org>.

SECTION X: ADDITIONAL GUIDANCE

The equipment covered by the B30 Standard is subject to hazards that cannot be abated by mechanical means, but only by the exercise of intelligence, care, and common sense. It is therefore essential to have personnel involved in the use and operation of equipment who are competent, careful, physically and mentally qualified, and trained in the proper operation of the equipment and the handling of loads. Serious hazards include, but are not limited to, improper or inadequate maintenance, overloading, dropping or slipping of the load, obstructing the free passage of the load, and using equipment for a purpose for which it was not intended or designed.

The B30 Standard Committee fully realizes the importance of proper design factors, minimum or maximum dimensions, and other limiting criteria of wire rope or chain and their fastenings, sheaves, sprockets, drums,

and similar equipment covered by the standard, all of which are closely connected with safety. Sizes, strengths, and similar criteria are dependent on many different factors, often varying with the installation and uses. These factors depend on

- (a) the condition of the equipment or material
- (b) the loads
- (c) the acceleration or speed of the ropes, chains, sheaves, sprockets, or drums

- (d) the type of attachments
- (e) the number, size, and arrangement of sheaves or other parts
- (f) environmental conditions causing corrosion or wear
- (g) many variables that must be considered in each individual case

The requirements and recommendations provided in the volumes must be interpreted accordingly, and judgment used in determining their application.

ASME B30.2-2011

SUMMARY OF CHANGES

Following approval by the ASME B30 Committee, and after public review, ASME B30.2-2011 was approved by the American National Standards Institute on May 31, 2011.

In ASME B30.2-2011, figures have been redesignated. ASME B30.2-2011 also includes editorial changes, revisions, and corrections identified by a margin note, **(11)**.

<i>Page</i>	<i>Location</i>	<i>Change</i>
viii–x	B30 Standard Introduction	Revised in its entirety
4	Section 2-0.2	Definition of <i>minimum breaking force</i> added
13	2-1.13.3	Subparagraph (l) revised
16	2-1.14.3	Subparagraph (a) revised and Note deleted
18–20	Chapter 2-2	Revised in its entirety
21–26	Chapter 2-3	Revised in its entirety
27–29	Chapter 2-4	Added

SPECIAL NOTE:

The interpretations to ASME B30.2-2011 are included in this edition as a separate section for the user's convenience.

INTENTIONALLY LEFT BLANK

OVERHEAD AND GANTRY CRANES

(TOP RUNNING BRIDGE, SINGLE OR MULTIPLE GIRDER, TOP RUNNING TROLLEY HOIST)

Chapter 2-0

Scope, Definitions, and References

SECTION 2-0.1: SCOPE OF B30.2

Volume B30.2 includes provisions that apply to the construction, installation, operation, inspection, and maintenance of hand-operated and power-driven overhead and gantry cranes that have a top-running single-girder or multiple-girder bridge, with one or more top-running trolley hoists used for vertical lifting and lowering of freely suspended, unguided loads consisting of equipment and materials (see Figs. 2-0.2-1 through 2-0.2-5). The requirements included in this Volume also apply to cranes having the same fundamental characteristics such as cantilever gantry cranes, semi-gantry cranes, and wall cranes.

Requirements for a crane used for a special purpose such as, but not limited to, non-vertical lifting service, lifting a guided load, or lifting personnel are not included in this Volume.

(11) SECTION 2-0.2: DEFINITIONS

abnormal operating conditions: environmental conditions that are unfavorable, harmful, or detrimental to or for the operation of a crane, such as excessively high or low ambient temperatures, exposure to adverse weather, corrosive fumes, dust-laden or moisture-laden atmospheres, and hazardous locations.

administrative or regulatory authority: governmental agency or, in the absence of governmental jurisdiction, the employer.

appointed: assigned specific responsibilities by the employer or the employer's representative.

authorized: appointed by a duly constituted administrative or regulatory authority.

auxiliary hoist: supplemental hoisting unit usually of lower load rating and higher speed than the main hoist.

boom (of gantry cranes): an extension of the trolley runway that may be raised or retracted to obtain clearance for gantry travel.

boom (of overhead cranes): a horizontal member mounted on the trolley to permit hoisting and lowering the load at a point other than directly under the hoist drum or trolley.

brake: a device, other than a motor, used for retarding or stopping motion by friction or power means.

brake, holding: a friction brake for a hoist that is automatically applied and prevents motion when power to the brake is off.

brake, mechanical load: an automatic type of friction brake used for controlling loads in a lowering direction. This unidirectional device requires torque from the motor to lower a load but does not impose any additional load on the motor when lifting a load.

braking means: a method or device used for stopping/holding motion by friction or power.

braking, control: a method of controlling speed by removing energy from the moving body or by imparting energy in the opposite direction.

braking, countertorque (plugging): a method of controlling speed by reversing the motor line voltage polarity or phase sequence to develop torque in the direction opposite the rotation of the motor.

braking, dynamic: a method of controlling speed by using the motor as a generator, with the energy being dissipated in resistors.

braking, eddy current: a method of controlling or reducing speed by means of an electrical induction load brake.

braking, emergency: a method of decelerating a drive when power is not available. The braking effort may be established as a result of action by the operator, or automatically when power to the drive is interrupted.

braking, hydraulic: a method of controlling or reducing speed by means of displacement of a liquid.

braking, mechanical: a method of controlling or reducing speed by friction.

braking, pneumatic: a method of controlling or reducing speed by means of compressed gas.

braking, regenerative: a method of controlling speed in which the electrical energy generated by the motor is fed back into the power system.

braking, service: a method to decelerate crane motion during normal operation.

bridge: that part of a crane consisting of one or more girders, trucks, end ties, footwalks, and drive mechanism, which carries the trolley or trolleys.

bridge travel: the crane movement in a direction parallel to the crane runway.

bumper (buffer): a device for reducing impact when a moving crane or trolley reaches the end of its permitted travel, or when two moving cranes or trolleys come into contact. This device may be attached to the bridge, trolley, or runway stop.

cab: the operator's compartment on a crane.

cab, normal: operator's compartment used for controlling a cab-operated crane.

cab, skeleton: operator's compartment used for occasional cab operation of a normally floor- or remote-operated crane.

cantilever frame: a structural member that supports the trolley of a wall crane.

clearance: distance from any part of the crane to the nearest obstruction.

collectors, current: contacting devices for collecting current from runway or bridge conductors.

conductors, bridge: the electrical conductors located along the bridge structure of a crane that transmit control signals and power to the trolley(s).

conductors, runway (main): the electrical conductors located along a crane runway that transmit control signals and power to the crane.

controller: a device, or group of devices, that serves to govern, in a predetermined manner, the power delivered directly to the apparatus to which it is connected.

controller, manual: a controller having all of its basic functions performed by devices that are operated by hand.

controller, spring-return: a controller that, when released, will return automatically to a neutral (off) position.

control panel: an assembly of components (magnetic, static, hydraulic, pneumatic, etc.) that governs the flow of power to or from a motor or other equipment in response to signals from a master switch, push-button

Fig. 2-0.2-1 Cantilever Gantry Crane

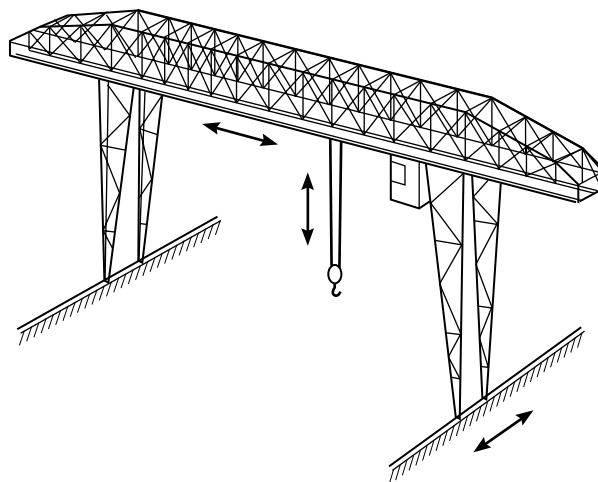

station, remote control, automatic program control, or other similar device.

crane: a machine for lifting and lowering a load and moving it horizontally, with the hoisting mechanism being an integral part of the machine.

crane, automatic: a crane which, when activated, operates through a preset cycle or cycles.

crane, cab-operated: a crane whose movements are controlled by an operator through the use of controllers located in a cab that is attached to the crane.

crane, cantilever gantry: a gantry or semigantry crane in which the bridge girders or trusses extend transversely beyond the crane runway on one or both sides (see Fig. 2-0.2-1).

crane, floor-operated: a crane whose movements are controlled by an operator through the use of controllers contained in a pendant station suspended from the crane.

crane, gantry: a crane similar to an overhead crane except that the bridge for carrying the trolley or trolleys is rigidly supported on two or more legs running on fixed rails or other runway (see Fig. 2-0.2-2).

crane, molten-material-handling: an overhead crane used for transporting or pouring molten material.

crane, manually operated: a crane whose hoist mechanism is driven by pulling an endless chain, or whose travel mechanism is driven in the same manner or by manually moving the load or hook.

crane, outdoor: an overhead or gantry crane that operates outdoors and for which provisions are not available for storage in an area that provides protection to the crane from weather conditions. An indoor crane that may operate outdoors on a periodic basis is not classified as an outdoor crane.

Fig. 2-0.2-2 Gantry Crane

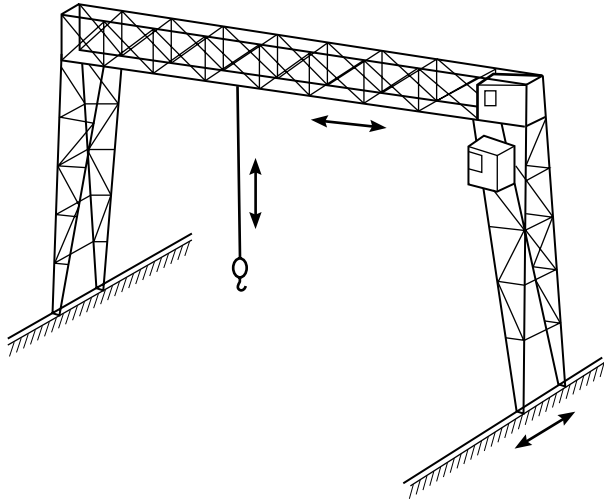

Fig. 2-0.2-4 Semigantry Crane

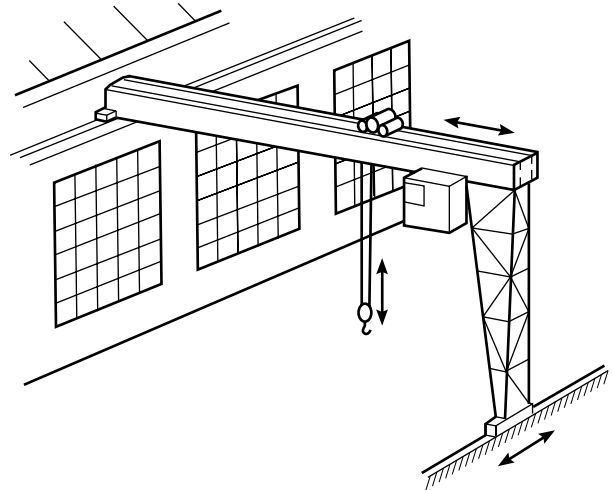

Fig. 2-0.2-3 Overhead Crane

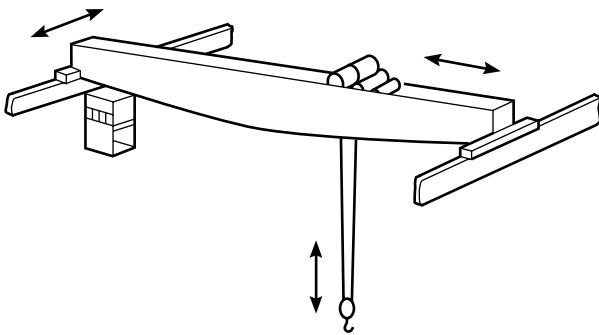
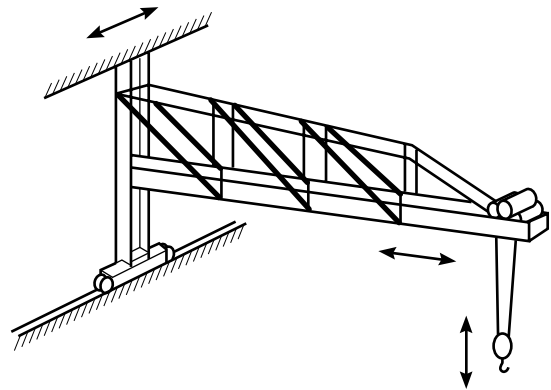

Fig. 2-0.2-5 Wall Crane



crane, overhead: a crane with a single or multiple girder movable bridge carrying a movable or fixed hoisting mechanism and traveling on an overhead fixed runway structure (see Fig. 2-0.2-3).

crane, polar: an overhead or gantry crane that travels on a circular runway.

crane, power-operated: a crane whose mechanism is driven by electric, pneumatic, hydraulic, or internal combustion means.

crane, pupil-operated: a crane whose movements are controlled by an operator through the use of controllers located in a control room or a fixed or movable cab or platform, that is independent of the crane.

crane, remote-operated: a crane whose movements are controlled by an operator through the use of controllers contained in a portable operating station not attached to the crane.

crane, semigantry: a gantry with one end of the bridge rigidly supported on one or more legs that run on a fixed rail or runway, the other end of the bridge being

supported by an end truck running on an elevated rail or runway (see Fig. 2-0.2-4).

crane, standby: a crane not in regular service that is used occasionally or intermittently as required.

crane, wall: a crane having a cantilever frame with or without trolley, and supported from a side wall or line of columns of a building. It is a traveling type and operates on a runway attached to the side wall or columns (see Fig. 2-0.2-5).

crane service, heavy: service that involves operating at 85 to 100% of rated load or in excess of 10 lift cycles/hr as a regular specified procedure.

crane service, normal: service that involves operating at less than 85% of rated load and not more than 10 lift cycles/hr except for isolated instances.

crane service, severe: service that involves normal or heavy service with abnormal operating conditions.

designated person: a person selected or assigned by the employer or the employer's representative as being competent to perform specific duties.

drift point: a point on a travel motion master switch or on a manual controller that maintains the brake released while the motor is not energized. This allows for coasting.

drum: the cylindrical member around which the ropes are wound for lifting or lowering the load.

end tie: a structural member that connects the ends of the bridge girders to maintain squareness of the bridge.

equalizer: a device that compensates for unequal length or stretch of a rope.

exposed: applies to hazardous objects not guarded or isolated, and capable of being contacted inadvertently.

gantry leg: the structural member that supports a bridge girder or end tie from the sill.

hazardous (classified) locations: locations where fire or explosion hazards may exist. Locations are classified depending on the properties of the flammable vapors, liquids, or gases, or combustible dusts or fibers that may be present and the likelihood that a flammable or combustible concentration or quantity is present (see National Electrical Code, ANSI/NFPA 70).

class I locations: locations in which flammable gases or vapors are or may be present in the air in quantities sufficient to produce explosive or ignitable mixtures.

class II locations: locations that are hazardous because of the presence of combustible dust.

class III locations: locations that are hazardous because of the presence of easily ignitable fibers or flyings, but in which such fibers or flyings are not likely to be in suspension in the air in quantities sufficient to produce ignitable mixtures.

hoist: a machinery unit that is used for lifting or lowering a freely suspended (unguided) load.

hoist motion: motion that lifts or lowers a load.

hook, latch-equipped: a type of hook with a mechanical device to close the throat opening of the hook.

lifting devices: devices that are not reeved onto the hoist ropes, such as hook-on buckets, magnets, grabs, and other supplemental devices used for ease of handling certain types of loads. The weight of these devices is to be considered part of the rated load.

limit device: a device that is operated by some part or motion of a power-driven hoist, trolley, or bridge to limit motion.

load: the total superimposed weight on the load block or hook.

load block: the assembly of hook or shackle, swivel, bearing, sheaves, pins, and frame suspended by the hoisting

rope or load chain. This shall include any appurtenances reeved in the hoisting ropes.

lockout/tagout: the placement of a lock/tag on the energy-isolating device in accordance with an established procedure.

main hoist: the primary hoist mechanism provided for lifting and lowering the rated load.

man trolley: a trolley having an operator's cab attached to it.

minimum breaking force: the minimum load at which a new and unused wire rope will break when loaded to destruction in direct tension.

noncoasting mechanical drive: a drive that automatically results in decelerating a trolley or bridge when power is not available.

normal operating conditions (of cab-operated cranes): conditions during which a crane is performing functions within the scope of the original design. Under these conditions, the operator is at the operating control devices, and there is no other person on the crane.

normal operating conditions (of floor-operated cranes): conditions during which a crane is performing functions within the scope of the original design. Under these conditions, the operator is at the operating control devices that are attached to the crane but operated with the operator off the crane, and there is no person on the crane.

normal operating conditions (of remote-operated cranes): conditions during which a crane is performing functions within the scope of the original design. Under these conditions, the operator is at the operating control devices that are not attached to any part of the crane, and there is no person on the crane.

overload: any load greater than the rated load (see para. 2-3.4).

parts of line: the number of lines of rope supporting the load block.

pendant station: controls suspended from the crane for operating the unit from the floor.

primary upper-limit device: the first device that, when actuated, limits hoisting motion in the upward direction.

qualified person: a person who, by possession of a recognized degree in an applicable field or a certificate of professional standing, or who by extensive knowledge, training, and experience, has successfully demonstrated the ability to solve or resolve problems relating to the subject matter and work.

rail sweep: a device attached to the crane and located in front of the crane's leading wheels to remove obstructions.

rated load (capacity): the maximum load designated by the manufacturer for which a crane or individual hoist is designed and built.

reeving: a system in which a rope travels around drums or sheaves.

rope: refers to wire rope unless otherwise specified.

runway: an assembly of rails, beams, girders, brackets, and framework on which the crane travels.

service platform: a means provided for workers to perform maintenance, inspections, adjustments, and repairs of cranes.

shall: this word indicates that a rule is mandatory and must be followed.

sheave: a grooved wheel or pulley used with a rope to change direction and point of application of a pulling force.

sheave, nonrunning (equalizer): a sheave used to equalize tension in opposite parts of the rope. Because of its slight movement, it is not termed a running sheave.

sheave, running: a sheave that rotates as the load block is lifted or lowered.

should: this word indicates that a rule is a recommendation, the advisability of which depends on the facts in each situation.

side pull: the portion of the hoist pull acting horizontally when the hoist lines are not operated vertically.

sills: horizontal structural members that connect the lower ends of two or more legs of a gantry crane on one runway.

slash (/): a slash (/) denotes and/or and indicates that two words are to be taken together or individually.

span: the horizontal distance, center to center, between runway rails.

stop: a device to limit travel of a trolley or crane bridge. This device normally is attached to a fixed structure and normally does not have energy-absorbing ability.

switch (valve): a device for making, breaking, or changing the connections in an electric, hydraulic, or pneumatic circuit.

switch, emergency stop: a manually actuated switch to disconnect power independently of the regular operating controls.

switch, limit: a device that is actuated by the motion of a part of a power-driven machine or equipment to alter or disconnect the electric, hydraulic, or pneumatic circuit associated with the machine or equipment.

switch, main (crane disconnect): a switch on the crane controlling the main power supply from the runway conductors.

switch, master: a switch that dominates the operation of contactors, relays, or other remotely operated devices.

switch, master, spring-return: a master switch that, when released, will return automatically to a neutral (off) position.

switch, runway disconnect: a switch, usually at floor level, controlling the main power supply to the runway conductors.

trolley: the unit that travels on the bridge rails and supports the load block.

trolley travel: the trolley movement.

truck: a unit consisting of a frame, wheels, bearings, and axles that supports the bridge girders, the end ties of an overhead crane, or the sill of a gantry crane.

unattended: a condition in which the operator of a crane is not at the operating control devices. However, on a floor-operated crane, if the operating control devices are within sight of the operator and within a distance equal to the span of the crane, the crane should be considered attended.

upper block: a fixed block located on a trolley that, through a system of sheaves, bearings, pins, and frame, supports the load block and its load.

SECTION 2-0.3: References

Within the text, references are made to the following publications, copies of which may be obtained from the publishers as indicated.

AISE Technical Report No. 6, June 1996, Specification for Electric Overhead Traveling Cranes for Steel Mill Service

Publisher: Association of Iron and Steel Technology (AIST), 186 Thorn Hill Road, Warrendale, PA 15086 (www.aist.org)

ANSI Z244.1-1982 (R1993), Safety Requirements for the Lock Out/Tag Out of Energy Sources

Publisher: American National Standards Institute (ANSI), 25 West 43rd Street, New York, NY 10036 (www.ansi.org)

ANSI A14.3-1992, Safety Requirements for Fixed Ladders¹

ANSI A1264.1-1995 (R2002), Safety Requirements for Workplace Floor and Wall Openings, Stairs, and Railing Systems¹

Publisher: American Society of Safety Engineers (ASSE), 1800 East Oakton Street, Des Plaines, IL 60018 (www.asse.org)

ANSI Z241.2-1999, Safety Requirements for Melting and Pouring of Metals in the Metalcasting Industry¹

Publisher: American Foundrymen's Society (AFS), 505 State Street, Des Plaines, IL 60016 (www.afsinc.org)

¹ May also be obtained from American National Standards Institute (ANSI), 25 West 43rd Street, New York, NY 10036.

ANSI Z535.4-1998, Product Safety Signs and Labels¹
Publisher: National Electrical Manufacturers Association (NEMA), 1300 North 17th Street, Rosslyn, VA, 22209 (www.nema.org)

ANSI/ASCE 7-98, Minimum Design Loads for Buildings and Other Structures¹
Publisher: American Society of Civil Engineers (ASCE), 1801 Alexander Bell Drive, Reston, VA 20191-4400 (www.asce.org)

ANSI/AWS D1.1-2002, Structural Welding Code — Steel¹
ANSI/AWS D14.1-97, Specification for Welding of Industrial and Mill Cranes and Other Material Handling Equipment¹
Publisher: American Welding Society (AWS), 550 NW Le Jeune Road, Miami, FL 33126 (www.aws.org)

ANSI/NFPA 70-2002, National Electrical Code¹
Publisher: National Fire Protection Association (NFPA), 1 Batterymarch Park, Quincy, MA 02269 (www.nfpa.org)

ANSI/SAE Z26.1-1996, Safety Glazing Materials for Glazing Motor Vehicles and Motor Vehicles Operating on Land Highways — Safety Standard¹
Publisher: Society of Automotive Engineers (SAE International), 400 Commonwealth Drive, Warrendale, PA 15096 (www.sae.org)

ASD Manual of Steel Construction, 9th Edition, 1989
LRFD Manual of Steel Construction, 2nd Edition, 2nd Revision, 1998
Publisher: American Institute of Steel Construction (AISC), One East Wacker Drive, Chicago, IL 60601 (www.aisc.org)

ASME B15.1-2000, Safety Standard for Mechanical Power Transmission Apparatus
ASME B30.9-1996, Slings
ASME B30.10-1999, Hooks
ASME B30.16-1998, Overhead Hoists (Underhung)
ASME B30.20-1999, Below-the-Hook Lifting Devices
Publisher: The American Society of Mechanical Engineers (ASME), Three Park Avenue, New York, NY 10016-5990; Order Department: 22 Law Drive, Box 2900, Fairfield, NJ 07007-2900 (www.asme.org)

CMAA Specification No. 70-2000, Specifications for Top Running Bridge and Gantry Type Multiple Girder Electric Overhead Traveling Cranes
Publisher: Crane Manufacturers Association of America (CMAA), 8720 Red Oak Boulevard, Charlotte, NC 28217 (www.mhia.org/industrygroups/cmaa)

Chapter 2-1

General Construction and Installation

SECTION 2-1.1: MARKINGS

2-1.1.1 Rated Load Markings — Crane

The rated load of the crane shall be marked on each side of the crane and shall be legible from the ground or floor.

2-1.1.2 Rated Load Markings — Hoists

(a) The rated load of the hoist shall be marked on the hoist or trolley unit or its load block and shall be legible from the ground or floor.

(b) If the crane has more than one hoisting unit, each hoist shall have its rated load marked as per para. 2-1.1.2(a).

2-1.1.3 Manufacturer's Identification Markings

The crane shall be marked with manufacturer's identification information, on a plate or label attached to the crane, as follows:

- (a) name and address of manufacturer
- (b) manufacturer's model or serial number
- (c) voltage of AC or DC power supply and phase and frequency of AC power supply

2-1.1.4 Multiple Hoist Identification Markings

If the crane has more than one hoisting unit, each hoist shall have an identification marking on the hoist or trolley unit or its load block (i.e., 1 and 2; A and B; north and south; etc.) and shall be legible from the ground or floor. These markings shall also appear on the controllers used by the operator to indicate the controllers that operate each hoist.

2-1.1.5 Warnings

(a) Floor-operated and remote-operated cranes shall have a safety label or labels affixed to the pendant station, portable operating station, or load block. The label or labels shall be in compliance with ANSI Z535.4, and shall include, but not be limited to, cautionary language against

- (1) lifting more than rated load
- (2) operating hoist when load is not centered under hoist
- (3) operating hoist with twisted, kinked, or damaged chain or rope
- (4) operating damaged or malfunctioning crane
- (5) lifting people
- (6) lifting loads over people

(7) operating a rope hoist with a rope that is not properly seated in its groove

(8) operating manual motions with other than manual power

(9) removing or obscuring safety label

(b) Cab-operated and pulpit-operated cranes shall have a safety label or labels affixed in the cab or pulpit. The label or labels shall be in compliance with ANSI Z535.4, and shall include, but not be limited to, cautionary language against

(1) lifting more than rated load

(2) operating hoist when load is not centered under hoist

(3) operating hoist with twisted, kinked, or damaged chain or rope

(4) operating damaged or malfunctioning crane

(5) lifting people

(6) lifting loads over people

(7) operating a rope hoist with a rope that is not properly seated in its groove

(8) removing or obscuring safety label

(c) A safety label shall be affixed on all electrical control enclosures. The label shall be in compliance with ANSI Z535.4, and shall include, but not be limited to, information such as the following:

(1) Disconnect power and lockout disconnecting means before removing cover or servicing this equipment.

(2) Do not operate without cover in place.

SECTION 2-1.2: CLEARANCES

2-1.2.1 Clearance From Obstruction

(a) Clearance shall be maintained between the crane and the building, as well as parallel running cranes and cranes operating at a different elevation, under all normal operating conditions. In the design of new cranes, all factors that influence clearance, such as wheel float, truss sag, bridge skewing, or trolley positions and configurations shall be considered.

(b) Where passageways or walkways are provided on the structure supporting the crane, obstructions shall not be placed so that personnel will be jeopardized by movements of the crane.

2-1.2.2 Clearance Between Parallel Cranes

If the runways of two cranes are parallel, and there are no intervening walls or structures, there shall be

clearance provided and maintained between the two bridges.

SECTION 2-1.3: GENERAL CONSTRUCTION — RUNWAYS AND SUPPORTING STRUCTURE

2-1.3.1 Foundations and Anchorages

(a) Permanent concrete or masonry foundations shall rest on footings below the frost line except in permafrost.

(b) Every outdoor crane shall be provided with secure fastenings convenient to apply and to hold the crane against a wind pressure of 30 lb/ft² (1 436 Pa). Parking brakes may be considered minimum compliance with this rule.

(c) Where wind forces are specified to be in excess of 30 lb/ft² (1 436 Pa), special anchorages, such as latches or tie-downs at the home position, or remotely operated rail clamps for all positions to supplement the primary braking system, shall be provided (ANSI/ASCE 7-88 may be used as a reference for this condition).

(d) Outdoor gantry cranes shall be provided with remotely operated rail clamps or other equivalent devices. Parking brakes may be considered minimum compliance with this rule.

(e) Rail clamps should only be applied when the crane is not in motion.

(f) When rails are used for anchorages, they shall be secured to withstand the resultant forces applied by the rail clamps. If the clamps act on the rail, any projection or obstruction in the clamping area shall be avoided.

(g) A wind-indicating device shall be provided for all outdoor cranes. The device shall be mounted on the crane or the crane runway structure and shall give a visible and audible alarm to the crane operator at a predetermined wind velocity. A single wind-indicating device may serve as an alarm for more than one crane.

2-1.3.2 Crane Runways

(a) *Construction of Runways and Rails*

(1) The crane runways and supporting structures shall be designed to withstand the loads and forces imposed by the crane. Steel crane runways and supporting structures should conform to the design parameters as specified in the applicable AISC Manual of Steel Construction.

(2) Runway columns shall be securely anchored to foundations.

(3) The structure shall be free from detrimental vibration under normal operating conditions.

(4) Rails shall be level, straight, joined, and spaced to the crane span within tolerances as specified in CMAA Specification No. 70, or within tolerances that are compatible with special conditions specified by the crane manufacturer or a qualified person.

(5) Where curves are required, special design will be necessary.

(6) Where grades are required, special design will be necessary.

(b) *Runway Stops*

(1) Stops shall be provided at the limits of travel of the bridge.

(2) Stops shall engage the bumpers or bumper pads mounted on the bridge.

(3) Stops shall be designed to withstand the forces applied to the bumpers, as specified in para. 2-1.8.2(b).

SECTION 2-1.4: CRANE CONSTRUCTION

2-1.4.1 Welded Construction

All welding procedures and welding operator qualifications to be used on load-sustaining members shall be in accordance with ANSI/AWS D1.1, except as modified by ANSI/AWS D14.1. Where special steels or other materials are used, the manufacturer or qualified person shall provide welding procedures.

2-1.4.2 Girders

All cranes built after the effective date of this volume should conform to the design parameters as specified, and applicable, in CMAA Specification No. 70 or AISE Technical Report No. 6.

2-1.4.3 Modifications

Cranes may be modified or rerated provided such modifications and the supporting structure are analyzed thoroughly and approved by a qualified person or manufacturer of cranes. A rerated crane or one whose load-supporting components have been modified shall be tested in accordance with para. 2-2.3.2. The new rated load shall be displayed in accordance with paras. 2-1.1.1 and 2-1.1.2.

SECTION 2-1.5: CABS — NORMAL OR SKELETON (IF PROVIDED)

2-1.5.1 Cab Location

(a) The general arrangement of the cab and the location of the control and protective equipment should be such that all operating handles are within reach of the operator when facing the area to be served by the load block, or while facing the direction of travel of the cab.

(b) The arrangement of the cab should allow the operator a full view of the load block in all positions. This is an important and desirable condition, but it is recognized that there are physical arrangements that may make this impossible, and, when the load block is in these positions, the operator shall be aided by other means such as, but not limited to, closed-circuit TV, mirrors, radio, telephone, or a signalperson.

(c) The cab shall be clear of all fixed structures within the area of possible movement.

(d) The clearance of the cab above the working floor or passageway should be not less than 7 ft (2.1 m), except when operations require dimensions that are less. In this case, precautions shall be taken during the operation of the crane to keep personnel and other obstructions clear of the low overhead.

2-1.5.2 Cab Construction

(a) The cab shall be constructed and attached to the crane to minimize swaying or vibrations.

(b) If an integral outside platform is provided, the door (if provided) shall be a sliding type or shall open outward.

(c) In the absence of an outside platform, the door (if provided) shall open inward or slide and shall be self-closing. It shall be equipped with positive latching devices to prevent inadvertent opening.

(d) The width of a doorway shall have a clear opening of not less than 18 in. (460 mm).

(e) A trapdoor (if provided) above the cab or in the cab roof, shall have a clear opening of not less than 24 in. (610 mm) on each side. There should be no obstructions in the opening path of the trap door that prevents opening of the trap door for the purpose for which it is designed.

(f) Guard railings and toeboards shall be in compliance with ANSI A1264.1.

(g) Outdoor cabs should be enclosed. All cab glazing shall be safety-glazing material, as defined in ANSI/SAE Z26.1.

(h) The cab construction shall offer protection from falling objects, if this possibility exists. The protection shall support 50 lb/ft² (2 400 Pa) static load.

(i) If the cab of a molten material crane is exposed to heat, it shall be provided with the following, or equivalent, protection:

- (1) cab enclosed as for outdoor protection
- (2) windows with metal sash and heat-resisting, safety-glazing material, as defined in ANSI/SAE Z26.1
- (3) floor insulated with heat-resistant material
- (4) a shield of metal at least $\frac{1}{8}$ in. (3 mm) thick located at least 6 in. (152 mm) below bottom of cab floor
- (5) materials that will not propagate combustion or rekindle

2-1.5.3 Access to Crane

Access to the cab or bridge walkway shall be by a fixed ladder, stairs, or platform. The ladder shall be in conformance with ANSI A14.3, except as modified to meet the requirements of this Volume.

2-1.5.4 Toolbox

If a receptacle is provided for the stowing of tools and oil cans, it shall be made of a noncombustible material

and shall be securely fastened in the cab or on the service platform.

2-1.5.5 Fire Extinguisher

A portable fire extinguisher, with a basic minimum extinguisher rating of 10 BC, shall be installed in the cab.

2-1.5.6 Lighting

Cab lighting, either natural or artificial, shall provide a level of illumination that enables the operator to observe the operating controls.

SECTION 2-1.6: LUBRICATION

If lubrication is required, accessible means for lubrication should be provided.

SECTION 2-1.7: SERVICE PLATFORMS (FOOTWALKS)

2-1.7.1 Construction of Service Platforms

Service platforms, when provided with or added to the crane, and attached to the crane, shall conform to the following requirements:

(a) The dimension of the working space in the vertical direction from the floor surface of the platform to the nearest overhead obstruction shall be a minimum of 48 in. (1 220 mm) at the location where a person is performing a function while on the platform.

(b) Crane travel shall be prohibited or restricted while a person is on a service platform and the overhead platform clearance is less than 78 in. (1 980 mm) at any location in the path of travel of the crane.

(c) Service platforms shall have a clear passageway at least 18 in. (457 mm) wide, except at the bridge drive mechanism where not less than 15 in. (380 mm) of clear passageway shall be allowed.

(d) The dimension of the working space in the direction of access to live (energized) electrical parts which are likely to require examination, adjustment, servicing, or maintenance while energized shall be a minimum of 30 in. (762 mm).¹

(e) The door(s) of electrical control cabinets shall either open at least 90 deg or be removable.¹

(f) Service platforms shall be designed to sustain a distributed load of at least 50 lb/ft² (2 400 Pa).

(g) Service platforms shall have a slip-resistant walking surface.

(h) Service platforms shall be provided with guard railings and toeboards.

(1) Guard railings and toeboards shall be in compliance with ANSI A1264.1.

(2) Guard railings shall be at least 42 in. (1 065 mm) high and shall be provided with an intermediate railing.

¹ Source: ANSI/NFPA No. 70, National Electrical Code.

2-1.7.2 Ladders and Stairways

(a) Gantry cranes shall be provided with ladders or stairways extending from the runway elevation to the footwalk or cab platform.

(b) Stairways shall be equipped with metal handrails and should be at an angle of not more than 50 deg with the horizontal. Walking surfaces shall be of a slip-resistant type.

(c) Ladders shall be fastened in place and shall be constructed in compliance with ANSI A14.3, except as modified to meet the requirements of this Volume.

2-1.7.3 Egress

There should be a means of egress from cab-operated cranes to permit departure under emergency conditions. The means of egress should depend on the facts of the situation.

SECTION 2-1.8: STOPS AND BUMPERS

2-1.8.1 Trolley Stops

(a) Stops shall be provided at the limits of travel of the trolley.

(b) Stops shall engage the bumpers or bumper pads mounted on the trolley, as specified in para. 2-1.8.3.

(c) Stops shall be designed to withstand the forces applied by the bumpers, as specified in para. 2-1.8.3.

2-1.8.2 Bridge Bumpers

(a) A power-operated bridge shall be provided with bumpers or other automatic means providing equivalent effect.

(b) Bridge bumpers shall have the following minimum characteristics:

(1) energy-absorbing (or energy-dissipating) capacity to stop the bridge when traveling with power off in either direction at a speed of at least 40% of rated load speed

(2) the capability of stopping the bridge (but not the load block or lifted load unless they are guided vertically) at a rate of deceleration not to exceed an average of 3 ft/sec² (0.9 m/s²) when traveling with power off in either direction at 20% of rated load speed and

(3) be designed and installed with a means of retaining the bumper in case of broken or loosened mounting connections

(c) Multiple power-operated bridges operating on the same runway shall have contact bumpers that meet the requirements of para. 2-1.8.2(b)(2).

(d) Consideration should be given to providing bumpers with greater capacity for energy absorption (or energy dissipation) than that specified in para. 2-1.8.2(b)(1) and providing bridge end stops with corresponding increased strength when any one of the following conditions are present:

(1) The crane has a maximum bridge speed of 320 ft/min (100 m/min) or greater.

(2) The crane is a remote-operated crane.

(3) The crane is a pulpit-operated crane.

(4) The location of the runway end stops is obscured or uncertain.

As an example, the bumper force applied at 100% of rated load speed is 625% greater than the bumper force applied at 40% of rated load speed.

2-1.8.3 Trolley Bumpers

(a) A power-operated trolley shall be provided with bumpers or other automatic means providing equivalent effect.

(b) Trolley bumpers shall have the following minimum characteristics:

(1) energy-absorbing (or energy-dissipating) capacity to stop the trolley when traveling with power off in either direction at a speed of at least 50% of rated load speed

(2) the capability of stopping the trolley (but not the load block or lifted load unless they are guided vertically) at a rate of deceleration not to exceed an average of 4.7 ft/sec² (1.4 m/s²) when traveling with power off in either direction at one-third of rated load speed

(3) be designed and installed with a means of retaining the bumper in case of broken or loosened mounting connections

(c) Multiple power-operated trolleys operating on the same bridge shall have contact bumpers that meet the requirements of para. 2-1.8.3(b)(2).

(d) Consideration should be given to providing bumpers with greater capacity for energy absorption (or energy dissipation) than that specified in para. 2-1.8.2(b)(1) and providing bridge end stops with corresponding increased strength when any one of the following conditions are present:

(1) The trolley has a maximum speed of 150 ft/min (46 m/min) or greater.

(2) The trolley is on a remote-operated crane.

(3) The trolley is on a pulpit-operated crane.

(4) The location of the trolley end stops is obscured or uncertain.

SECTION 2-1.9: RAIL SWEEPS

2-1.9.1 Bridge Rail Sweeps

(a) Bridge truck rail sweeps shall be provided in front of the leading wheels on both ends of the bridge end truck.

(b) The rail sweep shall clear the rail of objects on the runway which, if they came into contact between the wheel and rail, could cause damage to the wheel or derail the wheel.

(1) Clearance between the top surface of the rail head and the bottom of the sweep should not exceed $\frac{3}{16}$ in. (5 mm).

(2) On overhead crane end trucks, the sweep shall extend below the top surface of the rail head, for a distance not less than 50% of the thickness of the rail head, on both sides of the rail head.

(3) On gantry crane end trucks, when the rail head is located above the pavement or ground level, the sweep shall extend below the top surface of the rail head, for a distance not less than 50% of the thickness of the rail head, on both sides of the rail head.

(4) Clearance between the vertical inside surfaces of the sweep should be equal to the wheel tread width plus $\frac{3}{8}$ in. (10 mm), and clearance should be evenly spaced on each side of the wheel tread width.

2-1.9.2 Trolley Rail Sweeps

(a) Trolley truck rail sweeps should be provided in front of the leading wheels on both ends of the trolley end truck.

(b) The rail sweep shall clear the rail of objects on the bridge which, if they came into contact between the wheel and rail, could cause damage to the wheel or derail the wheel.

(1) Clearance between the top surface of the rail head and the bottom of the sweep should not exceed $\frac{3}{16}$ in. (5 mm).

(2) The sweep shall extend below the top surface of the rail head, for a distance not less than 50% of the thickness of the rail head, on both sides of the rail head.

(3) Clearance between the side surface of the rail head and the side of the sweep which extends below the top surface of the rail head should be equal to crane float plus $\frac{3}{16}$ in. (5 mm).

SECTION 2-1.10: GUARDS FOR MOVING PARTS

(a) Exposed moving parts, such as gears, set screws, projecting keys, and drive chain and sprockets, which constitute a hazard under normal operating conditions, shall be guarded.

(b) Each guard shall be capable of supporting, without permanent deformation, the weight of a 200 lb (90 kg) person, unless the guard is located where it is not probable that a person will step on it (see ASME B15.1).

SECTION 2-1.11: TRUCK FRAME DROP

Means shall be provided to limit the drop of bridge and trolley truck frames to 1 in. (25 mm) in case of wheel, axle, or bearing breakage.

SECTION 2-1.12: BRAKES AND BRAKING MEANS

2-1.12.1 Hoist Holding Brakes

(a) Each hoisting unit of the crane shall be equipped with at least one holding brake. The holding brake shall be applied to the motor shaft or a gear reducer shaft and shall have a torque rating not less than the percentage of rated load hoisting torque at the point where the brake is applied as follows:

(1) 125% of rated load hoisting torque when used with a control braking means other than mechanical

(2) 100% of rated load hoisting torque when used with a mechanical control braking means

(3) 100% of rated load hoisting torque for each brake if two holding brakes are provided

(b) Each hoisting unit of a crane that handles molten material shall be equipped with one of the following arrangements:

(1) Two holding brakes shall be provided, one of which is applied to a gear reducer shaft, plus control braking means. Each holding brake shall have a torque rating not less than 100% of rated load hoisting torque at the point where the brake is applied.

(2) One holding brake shall be provided if the hoisting unit has a mechanical load brake or a control braking means that provides controlled lowering of the load upon loss of power. The holding brake shall have a torque rating not less than 150% of rated load hoisting torque at the point where the brake is applied.

(c) Each hoist holding brake shall have thermal capacity for the frequency of operation required by the service.

(d) Hoist holding brakes shall be applied automatically when power to the brake is removed.

(e) Hoist holding brakes shall be provided with means to adjust for lining wear.

2-1.12.2 Hoist Control Braking Means

(a) Each hoisting unit of the crane shall be equipped with a control braking means that will control the load during lowering to a maximum speed of 120% of rated lowering speed for the load being handled.

(b) Hoist control braking means can be electrical, such as regenerative, dynamic, countertorque, or eddy-current; mechanical; hydraulic; or a worm-gear hoist where the angle of the worm is such as to prevent the load from accelerating in the lowering direction.

(c) Hoist control braking means shall have thermal capacity for the frequency of operation required by the service.

2-1.12.3 Trolley Brakes and Braking Means

(a) Each power-driven trolley unit of the crane shall be equipped with either a braking means or have trolley drive frictional characteristics that will provide stopping

and holding functions, under conditions where the rails are dry and free of snow and ice, as follows:

(1) have torque capability to stop trolley travel within a distance in feet (meters) equal to 10% of rated load speed in ft/min (m/min) when traveling with rated load

(2) have torque capability to impede horizontal motion of the trolley against a horizontal force equal to 1% of the combined weight of the trolley, hoist, and rated load when the trolley is in a parked condition

(b) A power-driven, cab-operated crane with the cab on the trolley shall be equipped with a trolley brake that will provide the stopping and holding functions described in paras. 2-1.12.3(a)(1) and (2).

(c) Each trolley brake shall have thermal capacity for the frequency of operation required by the service.

2-1.12.4 Bridge Brakes and Braking Means

(a) A power-driven bridge shall be equipped with either a braking means or have bridge drive frictional characteristics that will provide stopping and holding functions, under conditions where the rails are dry and free of snow and ice, as follows:

(1) have torque capability to stop bridge travel within a distance in feet (meters) equal to 10% of rated load speed in ft/min (m/min) when traveling with rated load

(2) have torque capability to impede horizontal motion of the bridge against a horizontal force equal to 1% of the combined weight of the bridge, trolley, hoist, and rated load when the bridge is in a parked condition

(b) A power-driven, cab-operated crane shall be equipped with a bridge brake that will provide the stopping and holding functions described in paras. 2-1.12.4(a)(1) and (2).

(c) Each bridge brake shall have thermal capacity for the frequency of operation required by the service.

2-1.12.5 Trolley and Bridge Brake Provisions

General provisions as outlined below apply to, as merited, trolley and bridge brakes.

(a) Brakes may be applied by mechanical, electrical, pneumatic, hydraulic, or gravitational means.

(b) Brakes shall be provided with means of adjustment to compensate for lining wear.

(c) Brake pedals, latches, and levers should allow release without the exertion of greater force than was used in applying the brake.

(d) Foot-operated brakes shall require an applied force of not more than 70 lb (310 N) to develop rated brake torque.

(e) Foot-operated brake pedals shall be so constructed that the operator's foot will not readily slip off the pedal.

(f) Foot-operated brake pedals should be so located that they are convenient to the operator at the controls.

(g) Foot-operated brakes shall be equipped with a means for positive release when force is released from the pedal.

(h) When provided, a parking brake shall

(1) be applied automatically or manually

(2) impede horizontal motion of the trolley or bridge in accordance with the requirements of para. 2-1.12.3(a)(2) or para. 2-1.12.4(a)(2)

(3) not prohibit the use of a drift point in the control circuit

(i) When provided, a service brake shall

(1) be applied manually by the operator during normal operation

(2) stop trolley or bridge travel in accordance with the requirements of para. 2-1.12.3(a)(1) or para. 2-1.12.4(a)(1)

(j) When provided, a drag brake shall provide a continuous retarding torque without external control.

(k) When provided an emergency brake shall

(1) be applied when initiated by the operator, or automatically upon loss of power

(2) stop trolley or bridge travel in accordance with the requirements of para. 2-1.12.3(a)(1) or para. 2-1.12.4(a)(1)

(3) impede horizontal motion of the trolley or bridge in accordance with the requirements of para. 2-1.12.3(a)(2) or para. 2-1.12.4(a)(2)

SECTION 2-1.13: ELECTRICAL EQUIPMENT

2-1.13.1 General

(a) Wiring and equipment shall comply with Article 610 of ANSI/NFPA No. 70, National Electrical Code.

(b) The control circuit voltage shall not exceed 600V for AC or DC.

(c) The control circuit voltage in pendant push buttons shall not exceed 150 V for AC or 300 V for DC.

(d) Where multiple conductor cable is used with a suspended push-button station, the station shall be supported so that the electrical conductors are protected from strain.

(e) Pendant control stations shall be constructed to prevent electrical shock. The push-button enclosure shall be at ground potential and marked for identification of functions.

2-1.13.2 Equipment

(a) Electrical equipment shall be located or enclosed so that, under normal operating conditions, energized parts will not be exposed to inadvertent contact.

(b) Energized parts of electrical equipment shall be protected from direct exposure to grease, oil, and moisture, and they should be protected from dirt.

(c) If guards are provided for energized parts, the guards shall be constructed or located so that they cannot be deformed, under normal operating conditions, to make inadvertent contact with energized parts.

(11) 2-1.13.3 Controllers

(a) Cranes not equipped with spring-return controllers, spring-return master switches, or momentary contact push buttons, shall be provided with a device that will disconnect all motors from the line in the event of a power failure. This disconnect device shall not permit any motor to be restarted until the controller or master switch handle is brought to the off position, or a reset switch or power-on button is operated.

(b) For cab- or pulpit-operated cranes, lever-operated manual controllers and master switches shall be provided with a spring-return arrangement, off-point detent, or off-point latch.

(c) For cab- or pulpit-operated cranes, the manual controller or master switch operating handle shall be located within reach of the operator.

(d) For cab- or pulpit-operated cranes, the movement of each operating handle should be in the same general direction as the resultant movement of the load, except as shown in Figs. 2-1.13.3-1 and 2-1.13.3-2.

(e) For cab- or pulpit-operated cranes, the arrangement of manual controllers or master switches should conform to Figs. 2-1.13.3-1 and 2-1.13.3-2.

(f) If a magnet controller is provided, the on (lift) direction shall be toward the operator and the off (drop) direction away from the operator.

(g) For floor-operated cranes, the controller or controllers, if rope operated, shall automatically return to the off position when released by the operator.

(h) Push buttons in pendant stations shall return to the off position when pressure is released by the crane operator.

(i) Automatic cranes shall be so designed that operation of all motions shall be discontinued if the automatic sequence control becomes ineffective. The completion of the last command is permissible if power is available.

(j) Remote-operated cranes shall function so that if the control signal for any crane motion becomes ineffective, that crane motion shall stop, and, conversely, signals received from any source other than the operating station (transmitter) shall not result in operation of any motion of the crane.

(k) The arrangement of pendant push-button stations and radio-control transmitters should conform to Figs. 2-1.13.3-3 and 2-1.13.3-4, respectively. Compass directions may be substituted for "right-left" and "forward-reverse" in Fig. 2-1.13.3-3, and for *W*, *X*, *Y*, and *Z* in Fig. 2-1.13.3-4.

(l) Basic controls (Figs. 2-1.13.3-1 through 2-1.13.3-4) used during crane operating cycle shall be located within reach of the operator while at the operating station and

labeled as to designated function and direction of movement.

2-1.13.4 Resistors

(a) Resistor units shall be supported to minimize vibration effect.

(b) Provisions shall be made to prevent broken parts or molten metal from falling on the operator or from the crane.

(c) If resistor enclosures are provided, the enclosures shall be installed so that the accumulation of combustible matter is minimized.

2-1.13.5 Switches

(a) The power supply to the runway conductors shall be controlled by a switch or circuit breaker located on a fixed structure, accessible from the floor, and arranged to be locked in the open position.

(b) On cab-operated cranes, a switch or circuit breaker of the enclosed type with provision for locking in the open position shall be provided in the leads from the runway conductors. A means of opening this device shall be located within the reach of the operator when the operator is in the operating position. When the operator opens this switch or circuit breaker, the holding brake(s) should set.

(c) On floor-, remote-, or pulpit-operated cranes, a device of the enclosed type shall be provided in the leads from the runway conductors. This device shall be mounted on the bridge or footwalk near the runway collectors. There shall be provisions for locking the device in the open position unless the crane is the only load on a lockable switch or circuit breaker that is accessible from the floor. One of the following types of floor-, remote-, and pulpit-operated disconnects shall be provided:

(1) nonconductive rope attached to the main disconnect device on a floor-operated crane. If this is selected, the rope shall be suspended adjacent to the operating ropes if manual controllers are used, or near the pendant push-button station if magnetic controls are used.

(2) an under-voltage trip for a main circuit breaker, operated by an emergency stop button in the pendant push-button station or the pulpit.

(3) a main line contactor operated by a switch or push button on the pendant push-button station, the remote control station, or the pulpit.

(d) Power-driven hoists shall be designed and constructed so that the load block, either loaded or empty, shall not exceed the upper limit of travel. On wire-rope hoists, if a geared or other limit switch or device that operates in relation to drum turns is used, an additional limit switch or device that operates independent of drum rotations shall be provided.

Fig. 2-1.13.3-1 Recommended Arrangement of Controllers or Master Switches (Three-Motor Crane)

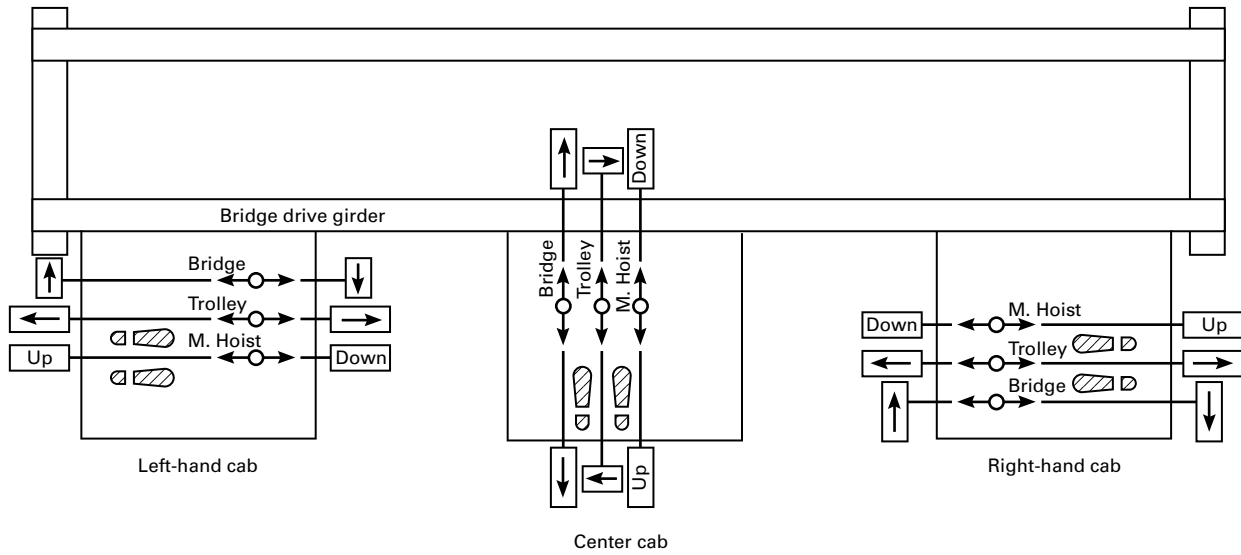

Fig. 2-1.13.3-2 Recommended Arrangement of Controllers or Master Switches (Four-Motor Crane)

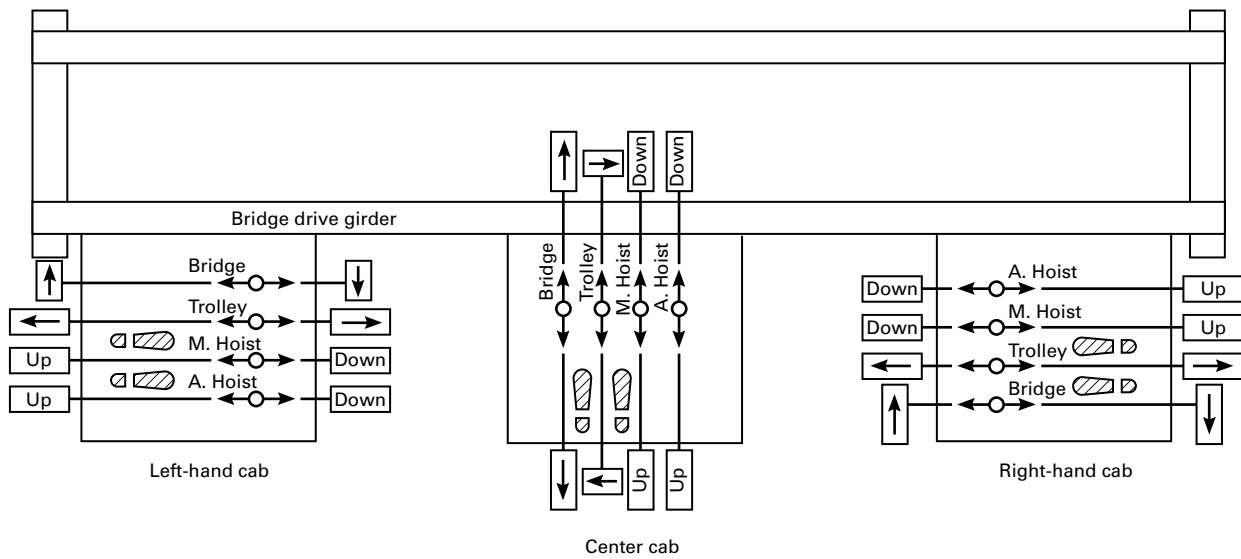
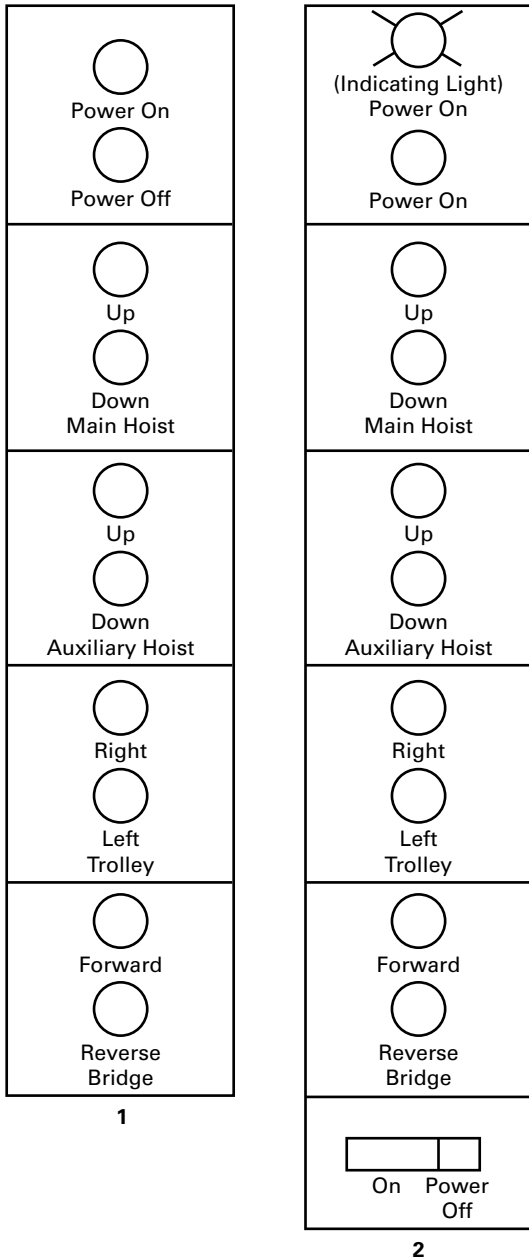
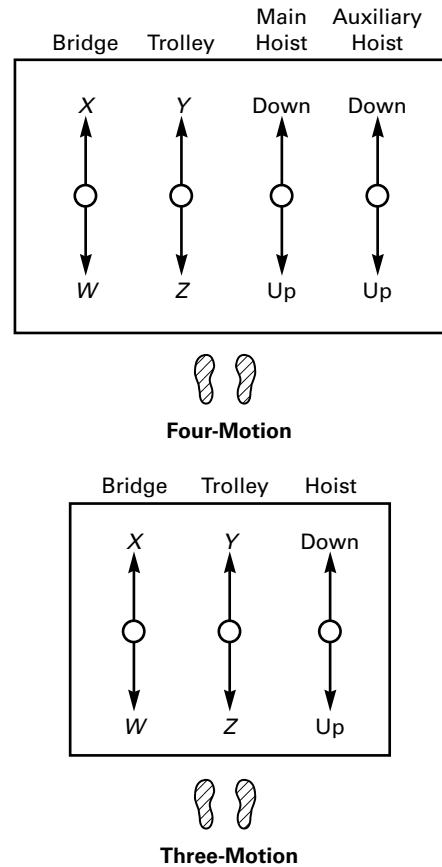

Fig. 2-1.13.3-3 Recommended Arrangement of Controllers (Pendant Push-Button Station Arrangement)



GENERAL NOTE: In each user location, the relative arrangement of units on crane pendant push-button stations should be standardized. In the absence of such standardization, suggested arrangements are shown in arrangements 1 and 2.

Fig. 2-1.13.3-4 Recommended Arrangement of Controllers (Radio Crane Control Transmitter Lever Arrangement)



GENERAL NOTE: Markings on the crane, visible from the floor, shall indicate the direction of bridge and trolley travel corresponding to the W, X, Y, and Z designations on the transmitter. The letters used are only intended for the purpose of illustration. Designations should be selected as appropriate to each illustration.

(e) Lower-travel-limit devices should be provided for power-driven hoists used in applications where the load block enters pits or hatchways in the floor.

2-1.13.6 Runway Conductors

Conductors of the open type, mounted on the crane runway beams or overhead, shall be so located or guarded that persons cannot inadvertently come into contact with the energized conductors under normal operating conditions or under maintenance procedures as stated in para. 2-4.2.3.

2-1.13.7 Lifting Magnets

(a) A crane for use with a lifting magnet shall have a separate magnet circuit switch of the enclosed type with provision for locking in the open (off) position. The magnet disconnect switch shall be connected on the line side (power supply side) of the crane disconnect switch.

(b) Means shall be provided for discharging the inductive load of a lifting magnet.

(c) Indication or signal lights should be provided to indicate that power to a lifting magnet is on or off. These lights, if used, shall be visible to the crane operator and to persons on the floor.

(d) For a remote-operated crane, the loss of the remote signal shall not result in demagnetizing the lifting magnet.

2-1.13.8 Extension Lamps

If a service receptacle is provided in the cab or on the bridge, it shall be a grounded-type permanent receptacle not exceeding 300 V.

SECTION 2-1.14: HOISTING EQUIPMENT

2-1.14.1 Sheaves

(a) Sheave grooves shall be free from surface defects which could cause rope damage. The cross-sectional radius at the bottom of the groove should be such as to form a close-fitting saddle for the size of rope used. The sides of the groove shall be tapered outward and rounded at the rim to facilitate entrance of the rope into the groove. Flange rims shall run true about the axis of rotation.

(b) Sheaves carrying ropes, which can be momentarily unloaded, shall be provided with close-fitting guards, or other devices, to guide the rope back into the groove when the load is reapplied.

(c) The sheaves in the bottom block shall be equipped with close-fitting guards that will minimize the possibility of ropes becoming fouled when the block is lying on the ground with the ropes loose.

(d) All running sheaves shall be equipped with means for lubrication. Permanently lubricated, sealed, or shielded bearings shall be acceptable.

2-1.14.2 Drums

Rope drums shall be grooved, except when the crane is provided by the manufacturer for a special application. This requirement does not preclude the use of multiple layer spooling. The grooves shall be free from surface defects that could cause rope damage. The cross-sectional radius at the bottom of the groove should be such as to form a close-fitting saddle for the size of rope used.

2-1.14.3 Ropes

(11)

(a) The hoisting ropes shall be of a recommended construction for crane service. The total load (rated load plus weight of load block) divided by the number of parts of line shall not exceed 20% of the minimum breaking force of the rope.

(b) Socketing shall be done in a manner recommended by the rope or fitting manufacturer or a qualified person.

(c) Rope shall be secured to the drum as follows:

(1) No less than two wraps of rope shall remain on the drum at each anchorage of the hoisting drum when the hook is in its extreme low position unless a lower-limit device is provided, in which case no less than one wrap shall remain.

(2) The rope end shall be anchored by a clamp attached to the drum, or by a socket arrangement specified by the crane or rope manufacturer. The rope clamps shall be tightened evenly to the manufacturer's recommended torque.

(d) Eye splices shall be made in recommended manner. Rope thimbles should be used in the eye.

(e) Wire rope clips shall be drop-forged steel of the single-saddle (U-bolt) or double-saddle type. Malleable cast iron clips shall not be used. For spacing, number of clips, and torque values, refer to the clip manufacturer's recommendation. Wire rope clips attached with U-bolts shall have the U-bolt over the dead end of the rope and live rope resting in the clip saddle. Clips shall be tightened evenly to the recommended torque. After the initial load is applied to the rope, the clip nuts shall be retightened to the recommended torque to compensate for any decrease in rope diameter caused by the load. Rope clip nuts should be retightened periodically to compensate for any further decrease in rope diameter during usage.

(f) Swaged or compressed fittings shall be applied as recommended by the rope, crane, or fitting manufacturer or qualified person.

(g) Wherever exposed to ambient temperatures at the rope in excess of 180°F (82°C), rope having an independent wire-rope or wire-strand core, or other temperature-damage-resistant core, shall be used.

(h) Replacement rope shall be the same size, grade, and construction as the original rope furnished by the crane manufacturer, unless otherwise recommended by

a rope or crane manufacturer or qualified person due to actual working condition requirements.

2-1.14.4 Equalizers

If a load is supported by more than one part of rope, the tension in the parts shall be equalized.

2-1.14.5 Hooks

Hooks shall meet the manufacturer's recommendations and shall not be overloaded. If hooks are of the swiveling type, they should rotate freely. Latch-equipped hooks shall be used unless the application makes the use of the latch impractical or unnecessary. When required, a latch or mousing shall be provided to bridge the throat opening of the hook for the purpose of retaining slings, chains, or other similar parts, under slack conditions (see ASME B30.10).

2-1.14.6 Guards for Hoisting Ropes

(a) If it is possible for hoisting ropes to foul or chafe on adjacent parts of the crane under normal operating conditions, guards shall be installed to minimize damage to the rope.

(b) A guard shall be provided to prevent contact between bridge or runway conductors and hoisting ropes if, under normal operating conditions, they can come into contact.

SECTION 2-1.15: WARNING DEVICES OR MEANS FOR A CRANE WITH A POWER-TRAVELING MECHANISM

2-1.15.1 Cab- and Remote-Operated Cranes

- (a) A warning device shall be provided.
- (b) Refer to para. 2-3.1.7(e) for operation of the device.

2-1.15.2 Floor-Operated Cranes

(a) A warning device should be provided for installations where the ability of the operator to warn persons in the path of the load is impaired.

(b) Refer to paras. 2-3.3.4(b)(18) and 2-3.3.4(c)(17) for operation of the device.

2-1.15.3 Types of Devices

One or more of the following devices shall be provided when required:

- (a) manually operated gong
- (b) power-operated bell, siren, or horn
- (c) rotating beacon
- (d) strobe light

SECTION 2-1.16: MANUAL

2-1.16.1 General Information

The crane manufacturer shall furnish with each crane at least one copy of the manual. The manual shall include general information applicable to the following:

- (a) installation
- (b) operation
- (c) inspection
- (d) testing
- (e) lubrication
- (f) maintenance
- (g) parts
- (h) wiring diagram (may be supplied separately)

2-1.16.2 Safety Personnel

Personnel responsible for the supervision, installation, operation, inspection, or maintenance of the crane shall be familiar with the applicable contents of the manual furnished with the crane.

(11)

Chapter 2-2

Inspection and Testing

SECTION 2-2.1: INSPECTION

2-2.1.1 General

(a) This Chapter on Inspection and Testing establishes and defines the criteria for determining whether cranes can be expected to perform as intended.

(b) Five types of inspections are defined, each with the common purpose of keeping equipment performing as intended. Each inspection is directed toward a different set of circumstances. The five types of inspection are

- (1) initial inspection
- (2) functional test inspection
- (3) frequent inspection
- (4) periodic inspection
- (5) inspection of equipment not in regular use

(c) In addition to the five types of inspection listed in para. 2-2.1.1(b), the inspection provisions found in manuals supplied by the manufacturer(s) of the crane and the crane components shall be followed.

(d) All inspections shall be performed by a designated person. Any deficiencies identified shall be examined and a determination made by a qualified person as to whether they constitute a hazard and if a more detailed inspection is required.

2-2.1.2 Initial Inspection

(a) An initial inspection is a visual and audible examination of the crane.

(b) New, reinstalled, altered, repaired, and modified equipment shall be inspected prior to initial use to verify compliance with the applicable provisions of Chapter 2-1 of this Volume.

(c) Inspection of altered, repaired, and modified cranes may be limited to the parts of the crane affected by the alteration, repair, or modification, as determined by a qualified person.

(d) The cranes shall be tested in accordance with the requirements of Section 2-2.3.

(e) Adjustments, repairs, or replacements necessary to satisfy requirements shall be made in accordance with para. 2-4.2.4 prior to initial use if the inspection and test reveal that there are items and conditions that do not comply with the provisions.

(f) Records of the inspection and test shall be made.

2-2.1.3 Functional Test Inspection

(a) A functional test inspection is a visual and audible operational examination of the crane, and shall be conducted at the beginning of each shift, or before the crane

is first used during each shift. In special applications, where the suspended load is transferred from operator to operator at shift change, the functional test inspection shall be performed when that lift is completed.

(b) Items that shall be inspected during performance of the functional test inspection are the following:

- (1) operational controls
- (2) upper limit device in accordance with para. 2-3.5(a)
- (3) rope in accordance with para. 2-2.2.2

(c) Adjustments, repairs, or replacements necessary to satisfy requirements shall be made in accordance with para. 2-4.2.4 prior to initial use if the functional test inspection reveals that there are items and conditions that do not comply with the provisions.

(d) Records of the inspection should be made.

2-2.1.4 Frequent Inspection

(a) A frequent inspection is a visual and audible examination of the crane.

(b) Equipment shall be inspected at intervals dependent on the use of the equipment as follows:

- (1) normal service — monthly
- (2) heavy service — weekly to monthly
- (3) severe service — daily to weekly

(c) The following items shall be inspected:

(1) operating mechanisms for proper operation, proper adjustment, and unusual sounds; such as, but not limited to, squeaking, grinding, grating, etc.

(2) upper limit device(s) in accordance with para. 2-3.5(a)

(3) tanks, valves, pumps, lines, and other parts of air or hydraulic systems for leakage

(4) hooks and latches, if used, in accordance with the provisions of ASME B30.10

(5) hook attachment and securing means

(6) rope for proper spooling onto the drum(s) and sheave(s)

(7) warning device(s) for proper operation

(8) rope in accordance with para. 2-2.2.2

(d) Adjustments, repairs, or replacements shall be made, as necessary, in accordance with para. 2-4.2.4.

(e) Records of the inspection should be made.

2-2.1.5 Periodic Inspection

(a) A periodic inspection is a visual and audible examination of the crane.

(b) Equipment shall be inspected at intervals dependent on the use of the equipment as follows:

- (1) normal service — yearly
- (2) heavy service — yearly
- (3) severe service — quarterly

(c) The inspection shall include the items listed in para. 2-2.1.4(c) and the following items, as applicable:

- (1) deformed, cracked, or corroded members.
 - (2) loose or missing fasteners, such as, but not limited to, bolts, nuts, pins, or rivets.
 - (3) cracked or worn sheaves and drums.
 - (4) worn, cracked, or distorted parts such as pins, bearings, wheels, shafts, gears, rollers, locking and clamping devices, bumpers, and stops.
 - (5) hooks, in accordance with the provisions of ASME B30.10.
 - (6) excessive wear of brake system parts.
 - (7) excessive wear of drive chain sprockets and excessive drive chain stretch.
 - (8) deterioration of controllers, master switches, contacts, limit switches, and push-button stations, but not limited to these items.
 - (9) wind indicators for proper operation.
 - (10) gasoline, diesel, electric, or other power plants for proper operation.
 - (11) motion limit devices that interrupt power or cause a warning to be activated for proper performance. Each motion shall be inched or operated at low speed into the limit device with no load on the crane.
 - (12) rope reeving for compliance with crane manufacturer's design.
 - (13) function, instruction, and safety information signs, labels, or plates for legibility and replacement.
 - (14) rope and end connections in accordance with para. 2-2.2.3.
- (d) Adjustments, repairs, or replacements shall be made, as necessary, in accordance with para. 2-4.2.4.
- (e) Dated records shall be made of apparent external conditions found in para. 2-2.1.5(c) to provide a basis for a continuing evaluation and placed on file.

2-2.1.6 Inspection of Cranes Not in Regular Use

(a) A crane that has been idle for a period of 1 mo or more, but less than 1 yr, shall be inspected before being placed in service in accordance with the requirements listed in para. 2-2.1.4.

(b) A crane that has been idle for a period of 1 yr or more, shall be inspected before being placed in service in accordance with the requirements listed in para. 2-2.1.5.

SECTION 2-2.2: ROPE INSPECTION

2-2.2.1 General

All inspections shall be performed by a designated person. Any deficiencies identified shall be examined

and a determination made by a qualified person as to whether they constitute a hazard and if a more detailed inspection is required.

2-2.2.2 Frequent Rope Inspection

(a) All ropes should be visually inspected at the start of each shift. These visual observations should be concerned with discovering gross damage, such as listed below, that may be a hazard.

- (1) distortion of the rope, such as kinking, crushing, unstranding, birdcaging, main strand displacement, or core protrusion
- (2) general corrosion
- (3) broken or cut strands
- (4) number, distribution, and type of visible broken wires [see paras. 2-4.3.1(b)(1) and (2) for further guidance]

(b) When damage as described in paras. 2-2.2.2(a)(1) through (a)(4) is discovered, the rope shall either be removed from service or given an inspection as detailed in para. 2-2.2.3(b).

2-2.2.3 Periodic Rope Inspection

(a) The inspection frequency shall be determined by a qualified person and shall be based on such factors as

- (1) expected rope life as determined by experience on the particular installation or similar installations
- (2) severity of environment
- (3) percent of capacity lifts
- (4) frequency rates of operation
- (5) exposure to shock loads

Inspections need not be at equal calendar intervals and should be more frequent as the rope approaches the end of its useful life.

(b) This inspection shall cover the entire length of rope. The individual outer wires in the strands of the rope shall be visible to the person during the inspection. Any deterioration resulting in appreciable loss of original strength, such as described below, shall be noted and determination shall be made as to whether further use of the rope would constitute a hazard.

- (1) points listed in para. 2-2.2.2(a).
- (2) reduction of rope diameter below nominal diameter due to loss of core support, internal or external corrosion, or wear of outside wires. See para. 2-4.3.1(b)(5).
- (3) severely corroded or broken wires at end connections.
- (4) severely corroded, cracked, bent, worn, or improperly applied end connections.

(c) Special care should be taken when inspecting sections of rapid deterioration, such as the following:

- (1) sections in contact with saddles, equalizer sheaves, or other sheaves where rope travel is limited

(2) sections of the rope at or near terminal ends where corroded or broken wires may protrude

(3) sections subject to reverse bends

(4) sections of rope that are normally hidden during visual inspection, such as parts passing over sheaves

(d) In order to establish data as a basis of judging the proper time for replacement, a continuing inspection record should be maintained. This record should cover points of deterioration listed.

SECTION 2-2.3: TESTING

2-2.3.1 Operational Tests

(a) New, reinstalled, altered, repaired, and modified cranes shall be tested by a designated person prior to initial use to confirm that the crane performs in compliance with the provisions of this Volume.

(b) Tests shall include, as applicable, the following functions:

- (1) lifting and lowering
- (2) trolley travel
- (3) bridge travel
- (4) hoist-limit devices

(a) The trip setting of hoist-limit devices shall be determined by tests with an empty hook comprising a series of runs, each at increasing hook speed up to the maximum speed, unless the hoist has only a single speed.

(b) The actuating mechanism of the upper-limit device shall be located or adjusted so that it will trip the device in sufficient time to prevent contact of the load block or load with any part of the trolley or bridge.

(5) travel-limiting devices

(6) locking and indicating devices, if provided

(c) Operational testing of altered, repaired, and modified cranes may be limited to the functions affected by the alteration, repair, or modification, as determined by a qualified person.

2-2.3.2 Load Test

(a) New, reinstalled, altered, repaired, and modified cranes should be load tested prior to initial use, as determined by a qualified person.

(b) Load testing of altered, repaired, and modified cranes may be limited to the functions affected by the alteration, repair, or modification, as determined by a qualified person.

(c) The replacement of load chain and rope is specifically excluded from this load test; however, an operational test of the hoist shall be made in accordance with para. 2-2.3.1 prior to putting the crane back in service.

(d) If a load test is conducted, the load shall be not less than 100% of the rated load of the crane or hoist(s), whichever governs; or more than 125% of the rated load of the crane or hoist(s), whichever governs; unless otherwise recommended by the manufacturer or a qualified person.

(e) If a load test is conducted, the person conducting the load test shall prepare a written report of the load sustained during the test and the operations performed during the test. Reports shall be placed on file.

(f) If a load test is conducted, operations shall be performed as outlined below or as modified by a qualified person.

(1) Hoist the test load a distance to ensure that the load is supported by the crane and held by the hoist brake(s).

(2) Transport the test load by means of the trolley for the full length of the bridge.

(3) Transport the test load by means of the bridge for the full length of the runway in one direction with the trolley as close to the extreme right-hand end of the crane as practical, and in the other direction with the trolley as close to the extreme left-hand end of the crane as practical.

(4) Lower the test load, and stop and hold the load with the brake(s).

Chapter 2-3

Operator Training and Operation

SECTION 2-3.1: CRANE OPERATOR TRAINING

2-3.1.1 Purpose of Crane Operator Training

Crane operator training shall be provided to promote proficient performance of a crane operator in conformance with the provisions of this Volume.

2-3.1.2 Crane Operator Training: General

(a) Training shall include those items that apply to the crane and the particular application of the crane. Refer to para. 2-3.1.3 as a guide for sources of training material.

(b) Training programs and their contents shall be based upon but not limited to

- (1) physical characteristics of the workplace.
- (2) performance characteristics and complexity of the crane.
- (3) type of load to be handled, such as, but not limited to the following:
 - (a) multiple piece loads
 - (b) raw materials
 - (c) bulk materials
 - (d) machine assemblies
 - (e) hot molten materials
 - (f) hot materials
 - (g) fragile or durable materials
- (4) responsibilities of the crane operator and other persons involved in the movement of the load. Refer to paras. 2-3.3.2 and 2-3.3.4.

2-3.1.3 Sources of Training Material

Examples of sources of training material are as follows:

- (a) information outlined in the manual provided with the equipment
- (b) information available through trade associations
- (c) government training resources such as the Department of Labor
- (d) organized labor groups
- (e) courses, seminars, and literature offered by manufacturers of cranes, consultants, trade schools, continuing education schools, employers, and manufacturers of crane component parts
- (f) requirements and recommendations found in National Consensus Standards such as this Volume

SECTION 2-3.2: TRAINING FOR PERSONS OTHER THAN CRANE OPERATORS

2-3.2.1 Scope

Other persons, such as, but not limited to, maintenance personnel, test personnel, and crane inspectors, when it is necessary to operate a crane in the performance of their duties, shall be trained in accordance with the training requirements of this Volume.

SECTION 2-3.3: OPERATION

2-3.3.1 Scope of Crane Operation

The operation of overhead and gantry cranes shall be in accordance with the provisions included in this Volume, and in manuals furnished by the manufacturer of the crane as required in para. 2-1.16. The requirements of paras. 2-3.3.3(c) and (d) for certification as an operator of a crane apply to both dedicated operators, whose primary job is the operation of a crane (cab or pulpit), and nondedicated operators who use a crane (floor or remote) as another tool in performing their job.

2-3.3.2 General Requirements

The following requirements shall be followed by all personnel involved with the crane operation:

- (a) A warning sign, lock, or tag that is on any switch that controls power to the crane, such as, but not limited to the crane disconnect, motion disconnect, or runway disconnect, shall not be removed by any person other than the person who placed the sign, lock or tag on the device.
- (b) Warning or safety signs, labels, plates, or tags furnished on the lifting equipment shall not be removed or obscured.
- (c) The crane shall not lift, lower or travel while anyone is on the load or hook.
- (d) The hoist rope shall be free from kinks or twists and shall not be wrapped around the load.
- (e) A hook latch shall be used when provided. (See para. 2-1.14.5.)
- (f) The hook latch (when provided) shall be closed and shall not be used to support any part of the load.
- (g) The load, sling, or lifting device shall be seated in the bowl of the hook.
- (h) The hoist rope shall be seated in the drum grooves and the sheave grooves.
- (i) Persons shall stay clear of a suspended load.

(j) Caution shall be exercised when using a crane having a lifting magnet, due to hazard of possible falling metal.

(k) The crane shall be used to lift loads vertically without side pull except when specifically authorized by a qualified person who has determined that

(1) the various parts of the crane will not be overstressed

(2) the hoist rope will not bear or rub against other members of the crane, such as girders or trolley frame, except members specifically designed for such contact

(3) such side pulls will not cause the hoist rope to be pulled out of the sheave or across drum grooves

(l) The crane shall not be used to lift loads in excess of the rated load of the crane except during properly authorized tests or planned engineered lifts in accordance with Section 2-3.4.

(m) A load-limiting device shall not be used to measure the weight of the load.

(n) The hoist rope shall be protected so far as is practical from weld spatter or other damaging contaminants.

2-3.3.3 Responsibilities of Management (Owners/ Users)

Management (owners/users) shall

(a) identify, document, and assign responsibilities of the crane operator and other persons involved in the movement of the load for each crane installation. (See paras. 2-3.3.2 and 2-3.3.4.)

(b) provide training to persons who will operate a crane.

(c) provide written and practical examinations that verify that the person has acquired the knowledge and skill to operate the particular crane(s) that will be operated by the person. The examinations shall be defined by the owner/user and in accordance with any local, state, and federal provisions that may apply.

(d) issue a certificate, or formal record, that verifies that the person has been trained and has passed the examination required in para. 2-3.3.3(c), or confirm that the person has a valid certificate or formal record that satisfies the requirements of para. 2-3.3.3(c).

2-3.3.4 Responsibilities of Crane Operators

(a) *Lifting and Moving the Load*

(1) Three phases of lifting and moving the load shall be addressed as follows:

(a) before the lift

(b) during the lift

(c) after the lift

(2) In most crane operations, all of the requirements listed in para. 2-3.3.4(b) are the responsibility of the operator of the crane.

(3) Rigging the load, attaching the load to the crane hook, and other tasks related to moving the load are

sometimes handled by persons other than the crane operator.

(4) Crane operation characteristics such as, but not limited to, the type of crane, cab, floor, pulpit, or remote operated, the vantage point of the operator, and the purpose for which the crane is being used are conditions that determine whether the crane operator or another person is responsible for lift and move functions.

(5) Assignment of responsibilities is determined, identified, and documented by management for each crane application.

(b) *Before the Lift.* Crane operators shall

(1) read and be familiar with the applicable provisions of crane equipment safety standards and the instructions listed in manual(s) provided with the equipment

(2) be familiar with controls, instructions, and warnings located on the lifting equipment

(3) operate the equipment only when physically and otherwise fit

(4) not energize the main switch (crane disconnect) if a warning sign, lock, or tag is on the device until the sign, lock, or tag is removed by the person who placed it on the device, or by an authorized person

(5) not remove a warning sign, lock, or tag that is on any switch that controls power to the crane, such as, but not limited to the crane disconnect, motion disconnect, or runway disconnect, if the sign, lock, or tag was placed on the device by another person

(6) place all controllers in the off position before closing the main line disconnect device

(7) verify that no worker is on or adjacent to the crane before closing the main switch (crane disconnect)

(8) perform a functional test inspection and test in accordance with the requirements of para. 2-2.1.3

(9) not remove or obscure the warning or safety labels, plates, or tags furnished on the lifting equipment

(10) be familiar with and understand hand signals (see Section 2-3.6 and Fig. 2-3.6.1-1)

(11) verify that the hook, bridge, and trolley travel in the same direction as shown on the controls

(12) verify that the hoist rope is free from kinks or twists and is not wrapped around the load

(13) attach the load to the hook or have the load attached to the hook by means of slings or other lifting devices

(14) verify that the load, sling, or lifting device is seated in the bowl of the hook

(15) use a hook latch when provided

(16) verify that the hook latch (when provided) is closed and not supporting any part of the load

(17) verify that the rope is seated in the drum grooves and in the sheave(s) grooves if there is or has been a slack rope condition

(18) activate the warning device, when a device is furnished

(a) before starting the bridge or trolley motion of the crane

(b) intermittently during travel of the crane when approaching persons in the path of the load

(19) board the crane (cab) only at authorized locations and designated boarding entrances

(20) verify that the transmitter selected is the correct transmitter for the crane to be operated

(c) *During the Lift.* Crane operators shall

(1) respond to signals from the person directing the lift or a designated signalperson.

(2) be responsible for the lift when a signalperson is not used.

(3) obey any stop signal regardless of who gives it.

(4) lift a load only if its weight and the weight of any lifting device are within the rated load of the crane and hoist(s) as marked on the crane and hoist load block or load blocks.

(a) The operator shall verify the weight of the total load if there is a question whether the total load to be lifted exceeds the rated load of the crane and/or hoist(s).

(b) The operator shall not use a load-limiting device to measure the load.

(c) A total load exceeding the rated load shall not be lifted except during properly authorized tests or planned engineered lifts in accordance with Section 2-3.4.

(5) stop the crane's functions in a controlled manner when the operator has doubt as to the safety of crane operations. Lift operations shall resume only after the safety concerns have been addressed.

(6) verify multiple part lines are not twisting around each other when the lift is made.

(7) take up slack rope carefully, lift the load a few inches (cm) to check the load holding brake action and verify that the load is secured, balanced, and positioned on the hook and in the sling or lifting device.

(8) minimize swinging of the load or load hook.

(9) maintain firm footing when operating lifting equipment.

(10) avoid sudden acceleration and deceleration of the load.

(11) use the crane to lift vertically, without side pull, except when specifically authorized by a qualified person who has determined that

(a) the various parts of the crane will not be overstressed

(b) the hoist rope will not bear or rub against other members of the crane, such as girders or trolley frame, except members specifically designed for such contact

(c) such side pulls will not cause the hoist rope to be pulled out of the sheaves or across drum grooves

(12) verify that the load and rigging are free to move and will clear all obstructions.

(13) check the hoist brake(s), if a load approaching the rated load is to be handled, by lifting the load a short distance and applying the brake(s).

(14) stop the lifting of the load before the upper limit device is engaged. The hoist limit device that controls the upper limit of travel of the load block shall not be used as an operating control in normal operation unless additional means are provided to prevent damage from overtravel.

(15) avoid carrying loads over people.

(16) concentrate on operating the crane and shall not allow attention to be diverted while operating the crane.

(17) activate the warning device, when a device is furnished

(a) before starting the bridge or trolley motion of the crane

(b) intermittently during travel of the crane when approaching persons in the path of the load

(18) promptly report, to the person responsible for the crane, any malfunction, unusual performance or sound, or damage of equipment that could indicate the need for adjustment, repair, or replacement in order to maintain proper operation.

(19) contact runway stops or another crane with caution for the safety of the operator and persons on or under the cranes.

(20) warn persons on or under a crane when contact is to be made with another crane prior to contact being made.

(21) place all controllers or master switches in the off position when power is interrupted during normal operation.

(22) check the controllers for correct direction of motion when power is restored after a power outage.

(23) follow the directions of the designated person in charge of the operation when two or more cranes are used to lift a load.

(24) not leave a suspended load unattended unless provisions have been made to provide auxiliary supporting means under the suspended load, or guards or barriers are utilized on the floor to prevent people from entering the area affected by the suspended load.

(25) not lower the load below the point where two wraps of rope remain on each anchorage of the hoisting drum unless a lower-limit device is provided, in which case, no less than one wrap shall remain.

(26) stop the lowering of the load before the lower limit device, if furnished, is engaged. The lower limit device shall not be used as an operating device during normal operation.

(27) properly secure an outdoor overhead or gantry crane when the wind indicating alarm is activated in accordance with the requirements listed in para. 2-1.3.1.

(28) use the harness or belt, if provided, for use with the transmitter or place the transmitter in the location intended for its support.

(29) not override safety devices on the transmitter.

(30) not wear gloves that interfere with the operation of the controls.

(31) shut off the transmitter when a power failure occurs.

(d) *After the Lift.* Crane operators shall

(1) lift the load block and attachments above the highest moveable obstruction under the crane when the crane is not in use

(2) notify the next operator if required adjustment, repair, or replacement has not been made

(3) properly secure an outdoor overhead or gantry crane when the crane is shut down

(4) open the crane main line disconnect device and the magnet disconnect switch (when applicable) before leaving the crane cab

(5) place the controllers in the off position, before leaving the controls of the crane

(6) shut off the power to pendant-operated cranes before leaving area

(7) shut off and store transmitter in a designated and protected location

SECTION 2-3.4: PLANNED ENGINEERED LIFTS

Lifts in excess of the rated load may be required from time to time on a limited basis for specific purposes such as new construction or major repairs. Every planned engineered lift exceeding the rated load shall be treated as a special and separate event. Limitations and planned requirements shall be applicable, as follows.

(a) Planned engineered lifts shall be limited to powered cranes having a load rating of 5 tons and above.

(b) When planned engineered lifts are made, the load shall not exceed 125% of the crane load rating, except as provided in 2-3.4(d).

(c) Planned engineered lifts shall be limited to two occurrences on any crane within any continuous 12 mo period, except as provided in 2-3.4(d). If greater lift frequency is desired, consideration shall be given to rerating or replacing the crane.

(d) The crane manufacturer shall be consulted if the planned engineered lift exceeds 125% of rated load or if the frequency of planned engineered lifts exceeds two during a continuous 12 mo period.

(e) Each planned engineered lift shall comply with the following requirements:

(1) A written review of the crane service history shall be prepared, including reference to previous planned engineered lifts, structural repairs, and modifications of original design.

(2) The design of the structural, mechanical, electrical, pneumatic, and hydraulic components of the crane

shall be reviewed by means of applicable calculations for the load to be lifted and approved by the crane manufacturer or a qualified person, in accordance with accepted crane design standards if the load to be lifted exceeds 125% of rated load or if the frequency of planned engineered lifts exceeds two during a continuous 12 mo period.

(3) The design of the crane-supporting structure shall be reviewed and approved by a qualified person for conformance to applicable design criteria. The crane support shall be inspected and any deterioration or damage shall be taken into consideration in design calculations for the load to be lifted.

(4) The crane shall be inspected in accordance with para. 2-2.1.5 just prior to making the lift.

(5) The lift shall be made under controlled conditions under the direction of a designated person in accordance with a previously prepared lift plan. All persons in the area of the crane shall be alerted that the lift is being made.

(6) The operator shall test the crane at the planned engineered load by lifting the load a short distance and setting the brakes. The lift shall only be continued if the brake stops and holds the load. Any failure to hold the load shall be corrected before proceeding with the lift.

(7) The crane shall be inspected in accordance with para. 2-2.1.5 after the lift is completed and prior to being used for the lifting of any other load.

(8) A record of the planned engineered lift, including calculations, inspections, and all distances moved, shall be placed on file for availability to appointed personnel.

(f) The rated load test specified in para. 2-2.3.2 is not applicable to planned engineered lift provisions.

SECTION 2-3.5: HOIST LIMIT DEVICES (SWITCHES)

(a) Prior to the initial use of any hoist during each shift, the operator shall verify operation of the upper limit device under no-load conditions. If more than one upper limit device is present, only the operation of the primary upper limit device need be verified. Care shall be exercised; the block shall be inched into the limit or run in at slow speed. If the device does not operate properly, the operator shall immediately notify the appointed person.



(b) The hoist limit device that controls the upper limit of travel of the load block shall not be used as an operating control in normal operation unless additional means are provided to prevent damage from overtravel.

SECTION 2-3.6: SIGNALS

2-3.6.1 Standard Signals

(a) Signals to the operator shall be in accordance with this Volume, unless voice communication (telephone, radio, or equivalent) is utilized.

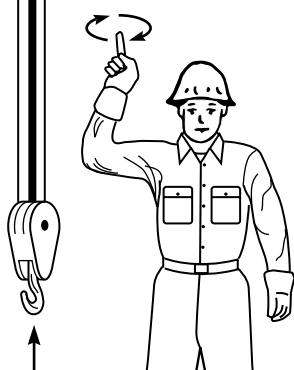
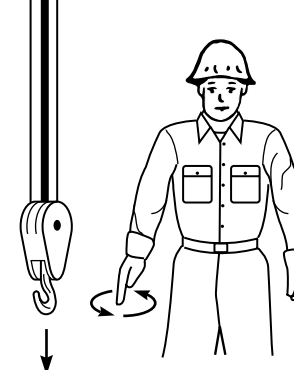
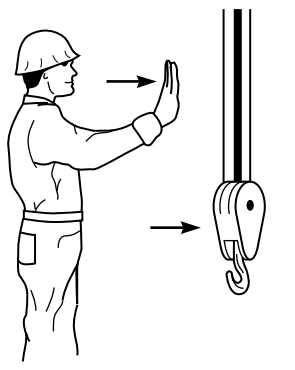
Fig. 2-3.6.1-1 Standard Hand Signals for Controlling Overhead and Gantry Cranes

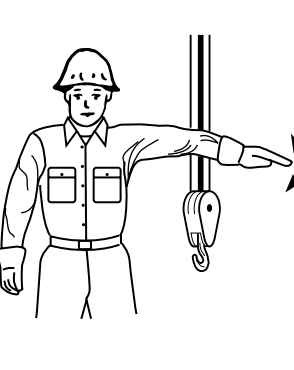
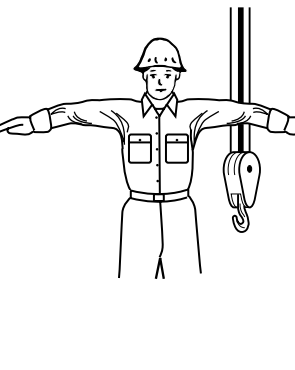
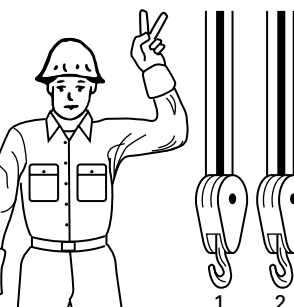
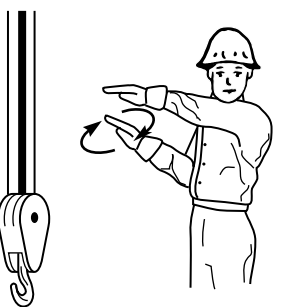
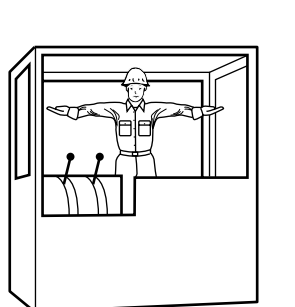
 <p>HOIST. With forearm vertical, forefinger pointing up, move hand in small horizontal circle.</p>	 <p>LOWER. With arm extended downward, forefinger pointing down, move hand in small horizontal circle.</p>	 <p>BRIDGE TRAVEL. Arm extended forward, hand open and slightly raised, make pushing motion in direction of travel.</p>
 <p>TROLLEY TRAVEL. Palm up, fingers closed, thumb pointing in direction of motion, jerk hand horizontally.</p>	 <p>STOP. Arm extended, palm down, move arm back and forth horizontally.</p>	 <p>EMERGENCY STOP. Both arms extended, palms down, move arms back and forth horizontally.</p>
 <p>MULTIPLE TROLLEYS. Hold up one finger for block marked "1" and two fingers for block marked "2". Regular signals follow.</p>	 <p>MOVE SLOWLY. Use one hand to give any motion signal and place other hand motionless in front of hand giving the motion signal. (Hoist slowly shown as example.)</p>	 <p>MAGNET IS DISCONNECTED. Crane operator spreads both hands apart — palms up.</p>

(b) Signals should be discernible or audible to the operator.

(c) Hand signals shall be posted conspicuously and should be as illustrated in Fig. 2-3.6.1-1.

2-3.6.2 Special Signals

(a) Special operations may require additions to or modifications of standard signals.

(b) Special signals shall be agreed upon and understood by the signalperson and the operator.

(c) Special signals shall not conflict with standard signals.

SECTION 2-3.7: MISCELLANEOUS

2-3.7.1 Ladders

(a) Hands shall be free from encumbrances while personnel are using ladders.

(b) Articles that are too large to be carried in pockets or tool belts shall be lifted and lowered by hand line.

2-3.7.2 Cabs

(a) Necessary clothing and personnel belongings shall be stored in a manner that does not interfere with access or operation.

(b) Tools, oil cans, rags, and other necessary articles shall be stored in the fire-resistant container and shall not be permitted to lie loose in or around the cab.

2-3.7.3 Fire Extinguishers

Operators shall be familiar with the location, operation, and care of fire extinguishers provided (see para. 2-1.5.5).

SECTION 2-3.8: CRANE LOCKOUT/TAGOUT

2-3.8.1 General

(a) A lockout/tagout policy and procedure shall be developed, documented, and implemented by the owner or user of overhead cranes.

(b) The lockout/tagout policy and procedure shall comply with the requirements of ANSI Z244.1.

(c) The policy shall give consideration to the following areas:

- (1) single-crane runways
- (2) multiple-crane runways
- (3) cranes on an adjacent runway
- (4) runway disconnecting means
- (5) crane disconnecting means
- (6) work to be done on the crane
- (7) work to be done other than on a crane but within the path of a crane where its movement creates a hazard

Chapter 2-4

Maintenance Training and Maintenance

SECTION 2-4.1: MAINTENANCE TRAINING

2-4.1.1 Purpose of Maintenance Training

Maintenance training shall be provided to promote proficient adjustments, repairs, and replacements on an overhead crane that will allow the crane to perform in accordance with the provisions of this Volume.

2-4.1.2 Crane Maintenance Training: General

This Volume of the B30 Standard recognizes that overhead and gantry cranes are used for many different purposes, handling many different kinds of loads in a variety of workplaces, and are maintained in a manner relative to these purposes, kinds of loads, and workplaces. Nevertheless, the requirements for certification as a crane maintenance person apply to all persons who maintain the mechanical, structural, and electrical components of a crane.

2-4.1.3 Sources of Training

Examples of sources of maintenance training material are as follows:

- (a) information outlined in the manual(s) provided by the equipment manufacturer
- (b) information available through trade associations
- (c) government training resources such as the Department of Labor
- (d) organized labor groups
- (e) courses, seminars, and literature offered by manufacturers of cranes, consultants, trade schools, continuing education schools, employers, and manufacturers of crane component parts
- (f) requirements and recommendations found in National Consensus Standards such as this Volume

2-4.1.4 Responsibilities of Crane Maintenance Personnel

Responsibilities of crane maintenance persons shall include, but not be limited to, the following items:

- (a) Read the applicable equipment safety standard referenced and the instructions outlined in the manuals(s) provided for the equipment by the equipment manufacturer.
- (b) Board a crane only at authorized locations and designated boarding entrances.
- (c) Not board a crane without the knowledge of the operator.

(d) Not attempt to repair electrical apparatus or to make other major repairs on the crane unless specific authorization has been received and the power is locked out/tagged out.

(e) Lower the load block to the ground or otherwise secure the load block before attempting any repairs or adjustments on the lifting equipment that would allow the load block to lower.

(f) Use replacement parts that are at least equal to the original manufacturer's specifications.

(g) Become familiar with wire rope replacement criteria.

(h) Install wire rope clamps correctly. Refer to the manual provided with the equipment.

(i) Not allow the wire rope or hook to be used as a ground for welding.

(j) Not allow the wire rope or hook to be touched by a live electrode.

(k) Not attempt to lengthen the wire rope, or repair a damaged rope.

(l) Not remove or obscure the warning or safety labels, plates, or tags furnished on the lifting equipment.

(m) Replace safety labels, plates, or tags when they are obscured or illegible.

(n) Replace all protective guards and panels before returning the crane to normal operation.

(o) Apply lubricant to the rope as recommended by the crane or rope manufacturer (or when relubricated).

SECTION 2-4.2: CRANE MAINTENANCE

2-4.2.1 General Maintenance

General maintenance should be performed in accordance with the conditions and practices of a particular workplace. Some factors that influence how maintenance is performed are:

- (a) if there are trained and experienced in-house maintenance persons such as mechanics or millwrights and electricians who can perform maintenance work on overhead and gantry cranes.
- (b) if an outside crane service company is contracted to do inspections, perform preventive maintenance, repairs, and replacements.
- (c) size of workplace and number of employees.
- (d) if the cranes have sophisticated performance characteristics such as reactor or adjustable frequency controls or basic single-speed or two-speed control systems.

2-4.2.2 Preventive Maintenance

A preventive maintenance program shall be established.

The program should be based on the recommendations outlined in the crane manufacturer's manual; and, when appropriate, additional recommendations outlined by a qualified person based upon review of the crane application and operation. Dated records should be placed on file.

2-4.2.3 Maintenance Procedure

(a) The following precautions shall be taken before performing maintenance on a crane or runway conductor system.

(1) The crane shall be moved to a location where it will cause the least interference with other cranes and operations in the area.

(2) If a load is attached to the crane, it shall be landed.

(3) All controllers shall be placed in the off condition.

(4) A lockout/tagout procedure shall be performed (see para. 2-3.8).

(5) Warning signs and barriers shall be utilized on the floor beneath the crane where overhead maintenance work creates a hazard.

(6) If the runway remains energized, stops or a signalperson(s), located full-time at a visual vantage point for observing the approach of an active crane(s), shall be provided to prohibit contact by the active crane(s) with the idle crane; with persons performing maintenance; and with equipment used in performing the maintenance.

(7) A guard or barrier shall be installed between adjacent runways for the length of any established work area to prevent contact between persons performing maintenance and a crane on the adjacent runway.

(b) Only designated persons shall work on energized equipment.

(c) After maintenance work is completed and before restoring the crane to normal operation

(1) guards shall be reinstalled

(2) safety devices shall be reactivated

(3) replaced parts and loose material shall be removed

(4) maintenance equipment shall be removed

2-4.2.4 Adjustments, Repairs, and Replacements

(a) Any condition disclosed by the inspections performed in accordance with the requirements of Section 2-2.1, that is determined to be a hazard to continued operation, shall be corrected by adjustment, repair, or replacement before continuing the use of the crane.

(b) Adjustments, repairs, and replacements shall be performed by designated personnel.

(c) Components shall be adjusted or repaired as needed. The following are examples:

(1) all operating mechanisms

(2) limit devices

(3) control systems

(4) brakes

(d) Repairs or replacements shall be made as needed. The following are examples:

(1) damaged or worn hooks as described under Maintenance in ASME B30.10. Repairs by welding or reshaping are not recommended.

(2) all critical parts that are cracked, broken, bent, excessively worn, or missing.

(3) pitted or burned electrical contacts should be corrected only by replacement and in sets. Controller parts should be lubricated as recommended in the manual supplied with the crane.

(4) function, instruction, caution, and warning labels or plates on pendant control stations shall be kept legible.

(e) If repairs of load sustaining members are made by welding, identification of materials shall be made and appropriate welding procedures shall be followed.

2-4.2.5 Lubrication

(a) All moving parts of the crane for which lubrication is specified should be regularly lubricated. Lubricating means should be checked for delivery of lubricant. Care should be taken to follow recommendations stated in the manufacturer's manual as to points and frequency of lubrication, maintenance of lubricant levels, and types of lubricant to be used.

(b) Machinery shall be stationary while lubricants are being applied, and protection provided as called for in paras. 2-4.2.3(a)(1) through (4) unless equipped for automatic or remote lubrication.

SECTION 2-4.3: ROPE REPLACEMENT AND MAINTENANCE

2-4.3.1 Rope Replacement

(a) No precise rules can be given for determination of the exact time for rope replacement, since many variable factors are involved. Once a rope reaches any one of the specified removal criteria, it may be allowed to operate to the end of the work shift, based on the judgment of a qualified person. The rope shall be replaced after the work shift, at the end of the day, or at the latest time prior to the equipment being used by the next work shift.

(b) Removal criteria for rope replacement shall be as follows:

(1) in running ropes, twelve randomly distributed broken wires in one lay or four broken wires in one strand in one lay

(2) one outer wire broken at the contact point with the core of the rope, which has worked its way out of

the rope structure and protrudes or loops out from the rope structure

(3) kinking, crushing, birdcaging, or any other damage resulting in distortion of the rope structure

(4) apparent heat damage from any heat source

(5) reductions from nominal rope diameter greater than 5%

(c) Broken wire removal criteria cited in this Volume apply only to wire rope operating on steel sheaves and drums. The user shall contact the sheave, drum, or crane manufacturer, or a qualified person, for broken wire removal criteria for wire ropes operating on sheaves and drums made of material other than steel.

(d) Attention shall be given to end connections. Upon development of two broken wires adjacent to a socketed end connection, the rope should be resocketed or replaced. Resocketing shall not be attempted if the resulting rope length will be insufficient for proper operation.

(e) Replacement rope shall have the same or higher minimum breaking force as the original rope specified by the hoist manufacturer. Any deviation from the original size, grade, or construction of the rope shall be specified by a rope manufacturer, the crane or hoist manufacturer, or a qualified person.

2-4.3.2 Rope Maintenance

(a) Rope should be stored to prevent damage or deterioration.

(b) Rope shall be unreeled or uncoiled in a manner to avoid kinking of or inducing a twist in the rope.

(c) Before cutting rope, means shall be used to prevent unlaying of the strands.

(d) During installation, care should be observed to avoid dragging the rope in dirt or around objects that will scrape, nick, crush, or induce sharp bends.

(e) Rope should be maintained in a well-lubricated condition. Lubricant applied as part of a maintenance program shall be compatible with the original lubricant. Lubricant applied shall be of the type that does not hinder visual inspection. Those sections of rope that are located over sheaves or otherwise hidden during inspection and maintenance procedures require special attention when the rope is being lubricated. The object of rope lubrication is to reduce internal friction and to prevent corrosion.

SECTION 2-4.4: MAINTENANCE RECORDS

Dated records should be kept on file.

INTENTIONALLY LEFT BLANK

ASME B30.2 INTERPRETATIONS

Replies to Technical Inquiries September 2005 Through January 2010

FOREWORD

This publication includes all of the written replies issued between the indicated dates by the Secretary, speaking for the ASME B30 Committee, Safety Standard for Cableways, Cranes, Derricks, Hoists, Hooks, Jacks, and Slings, to inquiries concerning interpretations of technical aspects of B30.2, Overhead and Gantry Cranes (Top Running Bridge, Single or Multiple Girder, Top Running Trolley Hoist).

These replies are taken verbatim from the original letters except for a few typographical corrections and some minor editorial corrections made for the purpose of improved clarity. In some few instances, a review of the interpretation revealed a need for corrections of a technical nature; in these cases, a corrected interpretation follows immediately after the original reply.

These interpretations were prepared in accordance with the accredited ASME procedures. ASME procedures provide for reconsideration of these interpretations when or if additional information is available which the inquirer believes might affect the interpretation. Further, persons aggrieved by this interpretation may appeal to the cognizant ASME Committee or Subcommittee. ASME does not "approve," "certify," "rate," or "endorse" any item, construction, proprietary device, or activity.

Interpretation: 2-53

Subject: ASME B30.2-2001, B30.11-1998, and B30.16-1998

Date Issued: September 26, 2005

Background: The following statement appears in para. 2-1.14.3 of ASME B30.2, para. 11-3.2.3 of ASME B30.11, and para. 16-1.2.6 of ASME B30.16.

“No less than two wraps of rope shall remain on the drum at each anchorage of the hoist(ing) drum when the hook is in its extreme low position unless a lower-limit device is provided, in which case no less than one wrap shall remain.”

Question (1): When the hook is in its “extreme low position,” does this mean that the hook is at its lowest point of travel when all of the rope has been unwound, except for the required wraps?

Reply (1): Yes.

Question (2): When the hook is in its “extreme low position,” does this mean that the hook must be capable of traveling all the way to the ground with no load?

Reply (2): No.

Interpretation: 2-54

Subject: ASME B30.2-1996, Section 2-0.2 Definitions

Date Issued: January 20, 2006

Background: The definition of *crane service, heavy*, states, “service that involves operating at 85 to 100% of rated load or in excess of 10 lift cycles/hr as a regular specified procedure.”

Question: Should a crane that has a rated capacity of 85 tons and performs one lift of 80 tons an average of once per month, and also performs one lift of 45 tons an average of every two weeks, be classified *heavy service* based upon the definition?

Reply: No. The service the crane is performing as described is in accordance with the definition of *normal service*, not *heavy service*, as long as the crane is not handling more than one lift of 80 tons an average of once per month and a 45 ton lift an average of every two weeks.

Interpretation: 2-55

Subject: ASME B30.2-2001, Paras. 2-3.2.3(a)(2) and 2-3.2.3(g)

Date Issued: January 20, 2006

Background: Paragraph 2-3.2.3(a)(2): The appointed person directing the lift shall ascertain that the load is secured, balanced, and positioned in the hook, sling or lifting device before the load is lifted more than a few inches (millimeters).

Paragraph 2-3.2.3(g): The operator shall check the hoist brake(s) at least once each shift if a load approaching the rated load is to be handled. This shall be done by lifting the load a short distance and applying the brake(s).

Question (1): Is the load lifted off the ground a short distance and then stopped in order to check the stability before proceeding with the lift, or is the procedure to tighten the rigging first, make sure the load is secure, balanced and positioned in the hook, sling or lifting device before the load comes off the ground and then start the lift and evaluate the load's stability as it is being lifted and traveled down the floor?

Reply (1): Paragraph 2-3.2.3(a)(2) does not require the lift to be stopped after it has been raised a few inches in order to check stability. It is a continuous process where the stability is evaluated during the first few inches and the lift is stopped only if a stability problem exists. Otherwise the lift continues. In the second scenario, even though the rigging may be tight and the load secured, it is not always possible to determine if the load is balanced while it is still on the ground.

Question (2): Are the requirements in paras. 2-3.2.3(a)(2) and 2-3.2.3(g) separate and distinct?

Reply (2): Yes. As stated in Reply (1), para. 2-3.2.3(a)(2) does not require that every lift be stopped. Therefore, it cannot be used to satisfy the requirement of para. 2-3.2.3(g).

Question (3): Can a specific or approximate distance be associated with the phrase, "lifted more than a few inches"?

Reply (3): No. It could be hazardous to try to meet a specific distance of lift in lieu of watching the balance and stability of the load. Also, in many cases the crane operator is the sole individual involved with the lift and it would be virtually impossible for him to lift to a specific height.

Interpretation: 2-56

Subject: ASME B30.2-2005, Crane Runways, Paras. 2-1.3.2, 2-1.4.3, and 2-2.2.2

Date Issued: September 21, 2006

Question (1): Does the standard require a load test for a modified runway structure that results in no runway capacity increase and no crane modification or capacity rating change? An example would be removing a runway column and installing a two column bent resulting in a load path change.

Reply (1): No, there is no requirement for load testing of the runway in the B30.2 volume.

Question (2): Does the standard require a load test for a modified runway structure that results in a runway capacity increase and no crane modification or capacity rating change? An example would be a two-crane runway to allow a third crane to be installed on the same runway.

Reply (2): No, there is no requirement for load testing of the runway in the B30.2 Volume.

Interpretation: 2-57

Subject: ASME B30.2-2005, Overhead and Gantry Cranes, Para. 2-1.13.5

Date Issued: July 7, 2008

Question (1): Does the standard permit the breaker to be on the ground floor?

Reply (1): Yes.

Question (2): Does the standard require a breaker or switch to be on each operating floor?

Reply (2): No.

Question (3): Does the standard permit the breaker or switch to be on just one operating floor?

Reply (3): Yes.

Note: This provision is consistent with ANSI/NFPA-70, the National Electrical Code.

Interpretation: 2-58

Subject: ASME B30.2-2005, Para. 2-2.1.1, Section 2-1.3, and Para. 2-2.2.1

Date Issued: June 10, 2009

Question (1): What are the requirements for testing the weighted upper final limit switch?

Reply (1): The requirements for testing the secondary weighted upper limit switch are given in para. 2-2.1.3(b)(10) for periodic inspection and paras. 2-2.2.1(b)(4)(a) and (b) for new, reinstalled, altered, repaired and modified cranes.

Question (2): Does ASME B30.2 require testing of a weighted upper final limit switch with the hoist at full speed?

Reply (2): For periodic inspection under para. 2-2.1.3(b)(10), the answer is "no." For new, reinstalled, altered, repaired, and modified cranes in paras. 2-2.2.1(b)(4)(a) and (b), the answer is "yes."

Question (3): Does ASME B30.2 require testing of a weighted upper final limit switch with the primary geared limit switch disabled?

Reply (3): For both periodic inspection under para. 2-2.1.3(b)(10) and for new, reinstalled, altered, repaired, and modified cranes in paras. 2-2.2.1(b)(4)(a) and (b), the answer is "yes."

Question (4): How often should the weighted upper final limit switch be tested?

Reply (4): The secondary weighted upper final limit switch shall be inspected according to the periodic inspection frequency requirements in para. 2-2.1.1(b)(2). For new, reinstalled, altered, repaired, and modified cranes, it shall be inspected according to para. 2-2.2.1(a).

Question (5): Are the testing requirements for the weighted upper final limit switch different for DC cranes as compared to AC frequency drive cranes?

Reply (5): No.

Interpretation: 2-59

Subject: B30.2-2005, Para. 2-3.1.7(f), Conduct of Operators

Date Issued: October 28, 2009

Background: Our situation is a lift was not able to be completed, placing the load back was deemed more hazardous. Our solution was to leave the overhead crane connected to the load. Due to balance concerns the load was placed on the ground but not all the weight loaded to the floor (25 tons on the crane 10 tons on the floor) and we didn't have enough time to do the job we could not leave a crane operator in the cab.

Question (1): Since we had contact with the floor have we landed the load?

Reply (1): No.

Question (2): Does all of the weight have to be loaded to the floor in order for the item to be considered landed?

Reply (2): Yes.

Interpretation: 2-60

Subject: B30.2-2005, Para. 2-2.2.2(d), Load Test

Date Issued: January 28, 2010

Background: Your request for interpretation refers to wording last included in para. 2-2.2.2 Rated Load Test of ANSI B30.2-1976 edition. The current wording in ASME B30.2-2005, para. 2-2.2.2(d) states, "If a load test is conducted, the load shall be not less than 100% of the rated load of the crane or hoist(s), whichever governs; or more than 125% of the rated load of the crane or hoist(s), whichever governs; unless otherwise recommended by the manufacturer or a qualified person." Based on the current wording our response to your inquiry is as follows:

Question (1): Can a load test be conducted using test weights equal to 100% of the rated capacity?

Reply (1): Yes.

Question (2): If the test weights are 100% of the rated capacity can the load rating be certified at 100% of the test weights/rated capacity?

Reply (2): ASME does not certify any activity, however the load rating can be verified at 100% of the rated capacity.

INTENTIONALLY LEFT BLANK

ASME B30.2-2011

ISBN 978-0-7918-3340-7



9 780791 833407



J08911